

MARCH 2024 EDITION

INDUSTRIAL DESIGN PORTFOLIO  
**FRIDA NECKMAR**

HEJ  
HELLO  
HI!



I'm Frida—a hands-on designer driven by a passion for crafting experiences and collaborating with others. Nature's beauty and its intriguing shapes inspire me, particularly when it comes to problem-solving and ergonomics. Having grown up in a creative family running our own flower shop, I've always been deeply involved in the business, learning invaluable lessons along the way.

Besides design, I'm also into entrepreneurship, sales, up-cycling, and event planning. My ultimate goal? To design products that make a positive impact and are cherished by those who use them.

I'm always ready to take on new challenges!"

# FRIDA NECKMAR

## SKILLS

### SOFTWARE

InDesign, Illustrator, Photoshop, PowerPoint, Fusion360, Blender, RhinoCeros 3D, KeyShot, Sketchbook, Meshmixer, Solidworks, Figma

### DRIVERS LICENSE

B license since 2017

### LANGUAGE

Swedish - native  
English - fluent  
Spanish & Italian - basic

## EDUCATIONS

2023 - present

Master's programme in Advanced Product Design  
*Umeå Institute of design, Umeå University, Sweden*

2019 - 2023

Bachelor of Industrial Design  
*Faculty of engineering, Lund University, Lund, Sweden*

2014 - 2017

Economics, Enterprise and Business  
*Procivitas Privata Gymnasium, Malmö, Sweden*

## INTERNSHIPS

March 2022 -  
Aug 2022

Tatic Design Studio, Milan, Italy  
*Product Design, Industrial Design*

Sept 2022 -  
Jan 2023

Philips, Amsterdam, Netherlands  
*Product Design, Grooming & Beauty*

## FREELANCE

2021

Polynom Investment  
*Logotype Design*

2013 - 2023

Blomsterpigan  
*Decorator, graphic & product design*

## WORK

2023  
*Part time*

Prosecco Sweden  
*Sales & events*

2017 - 2023  
*Full-time & part-time*

Lotta Jewellery  
*Shop assistant & Store manager, Handyman, Decorator, Model, Graphic Designer, Content creator, Marketing*

2014 - 2023  
*Part time*

Restaurants: Bloom in the Park, Namu, Flädie Mat och Vingård, Nyströms  
Gastronomi,  
*Waitress, events & weddings*

*Reference on demand*



# CONTENT

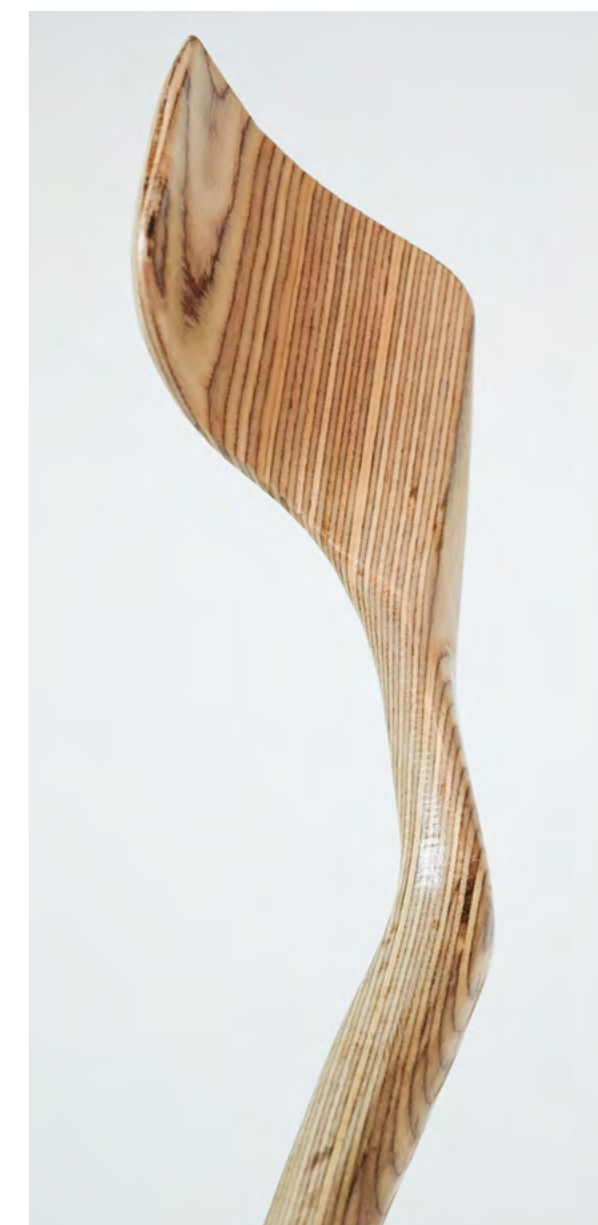
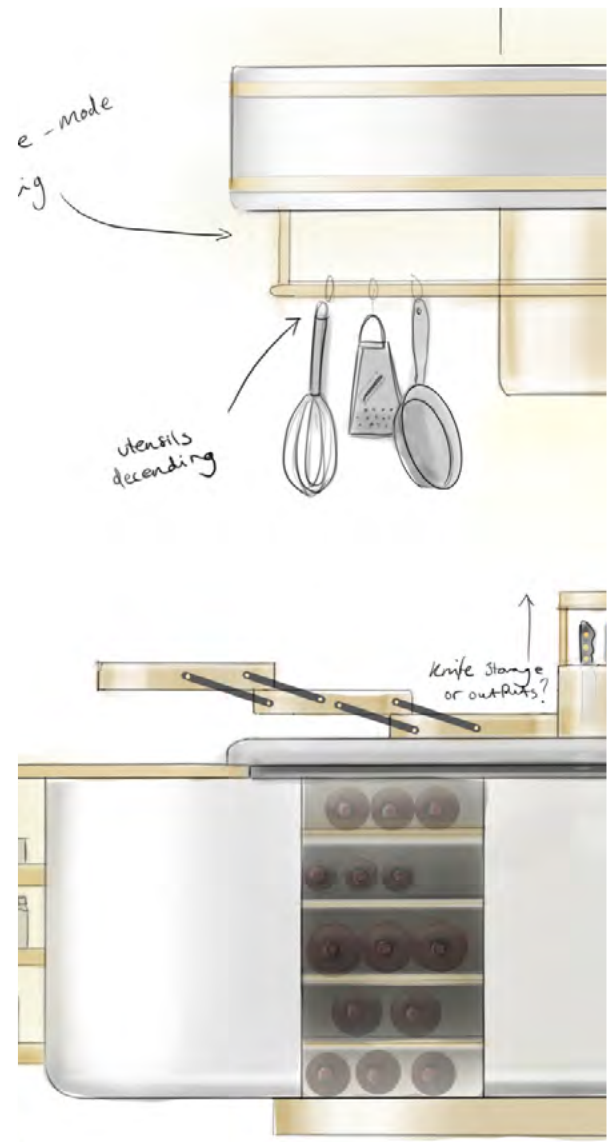



*Learnings*

- Parametric modelling
- Design for refurbishment
- Design for production
- Brand identity
- Form

# SCREWDRIVER

Electric screwdriver designed for easy refurbishment, with focus on designing for production.





# BRAND BOARD FISKARS®



## CMF

Debossed faded dot pattern, Soft Grip

High contrast material change

Rubber orange, black plastic, stainless steel, white graphics

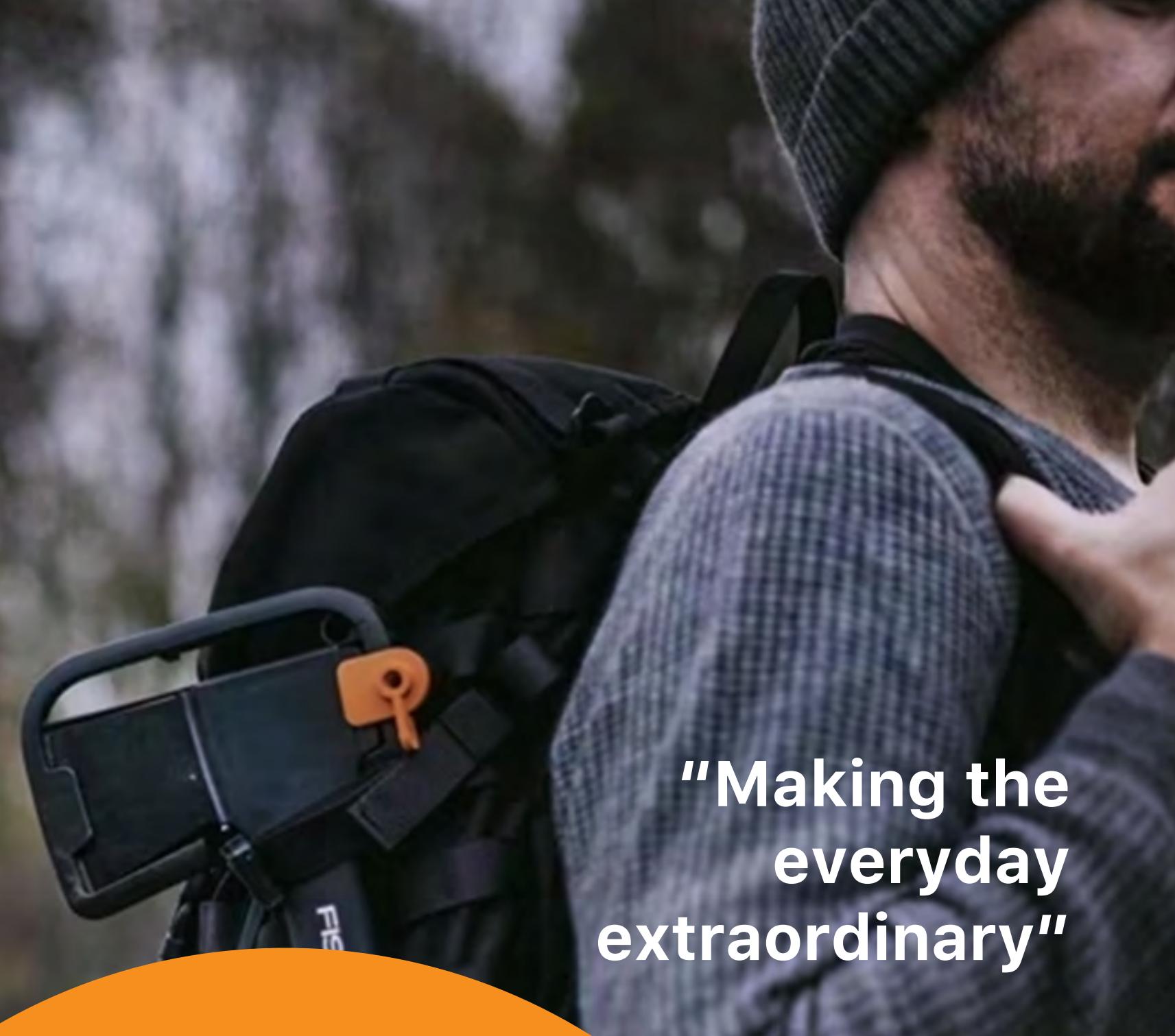
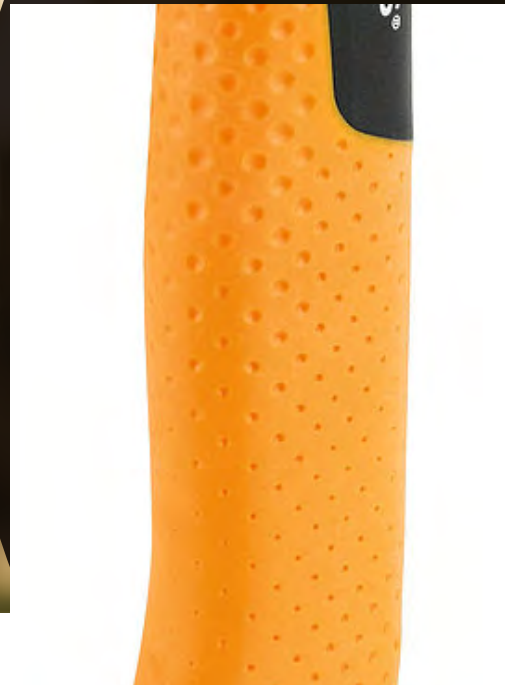

“Making the everyday extraordinary”

## FORM

Pill-shape/circular

Organic, elegant, Inspired by nature

Dynamic, angular split lines & accents



RELIABLE  
QUALITY  
PERFORMANCE

ERGONOMY  
CONSISTENT  
NATURAL

## CONTEXT

Hanging/laying archetype

Ergonomic tools

Smart solutions

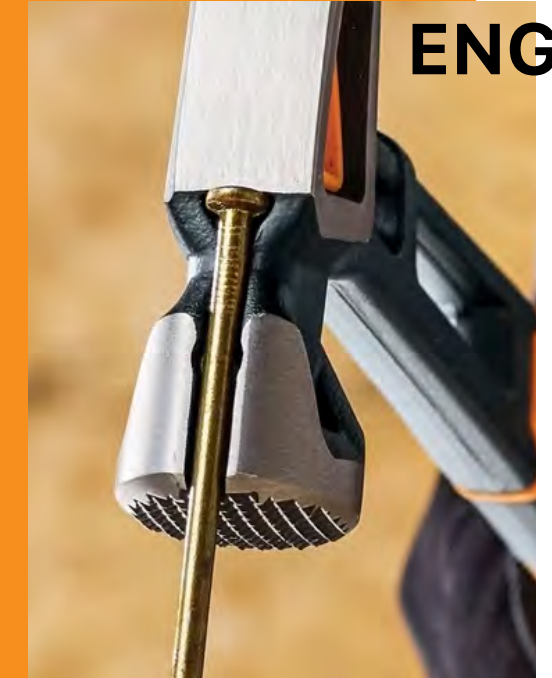

ADVANCED  
HUMAN  
ENGINEERING



First sketch

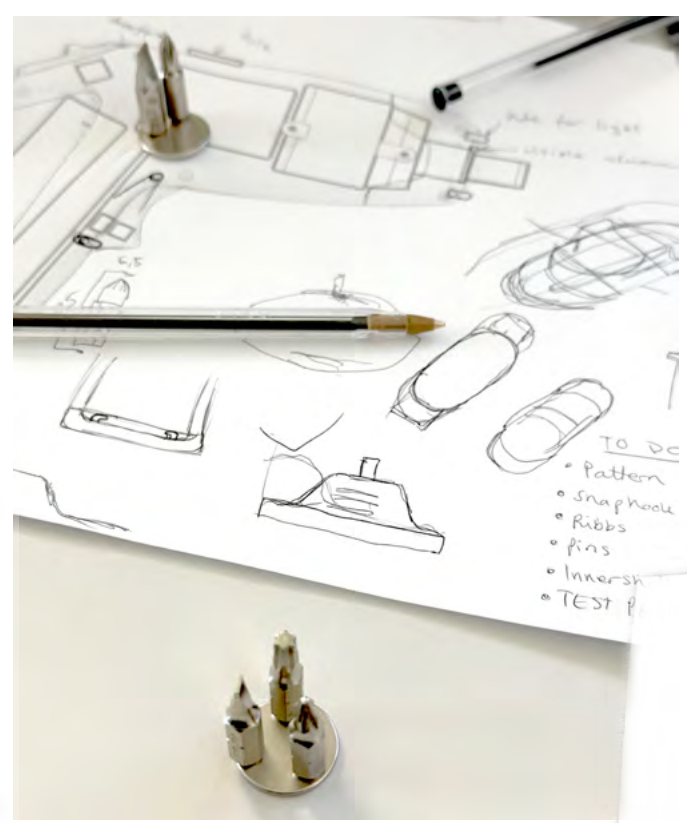
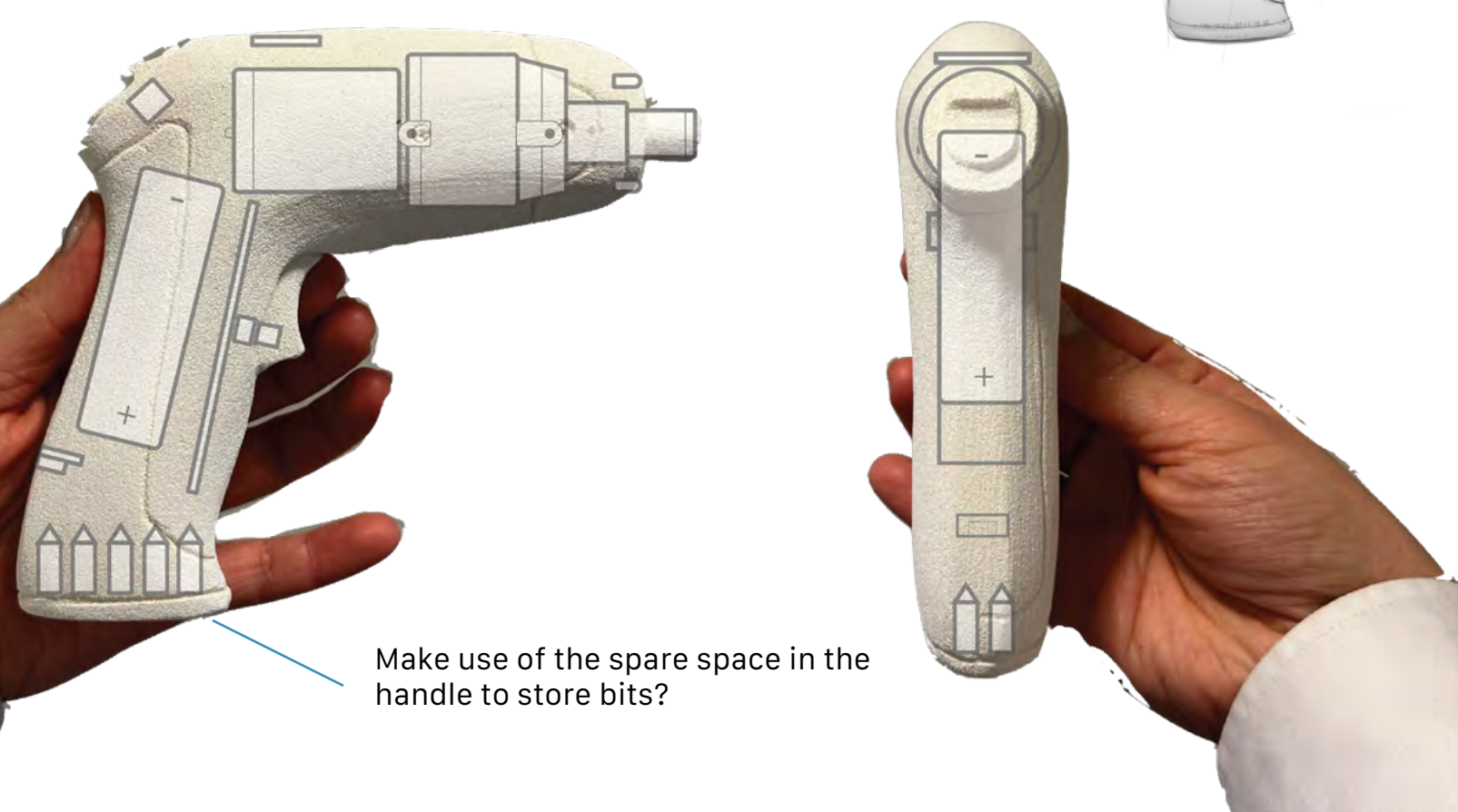
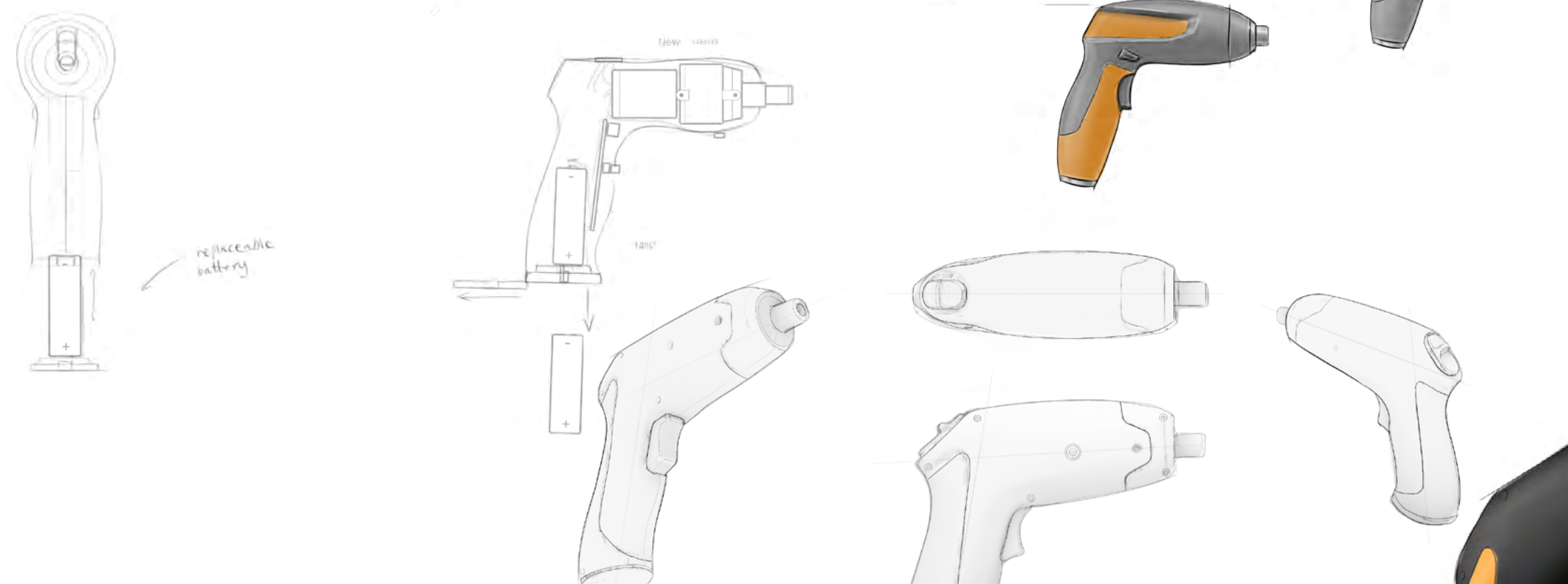

I utilized doodles on top of sketches to communicate ideas, variations, possible changes, measurements and "to do's" while modelling

Magnets or no magnets for the bits-holder?  
Magnets achieves a very satisfying user experience and sound, but it would make the products less environmental friendly, more expensive to produce and complicate recycling.

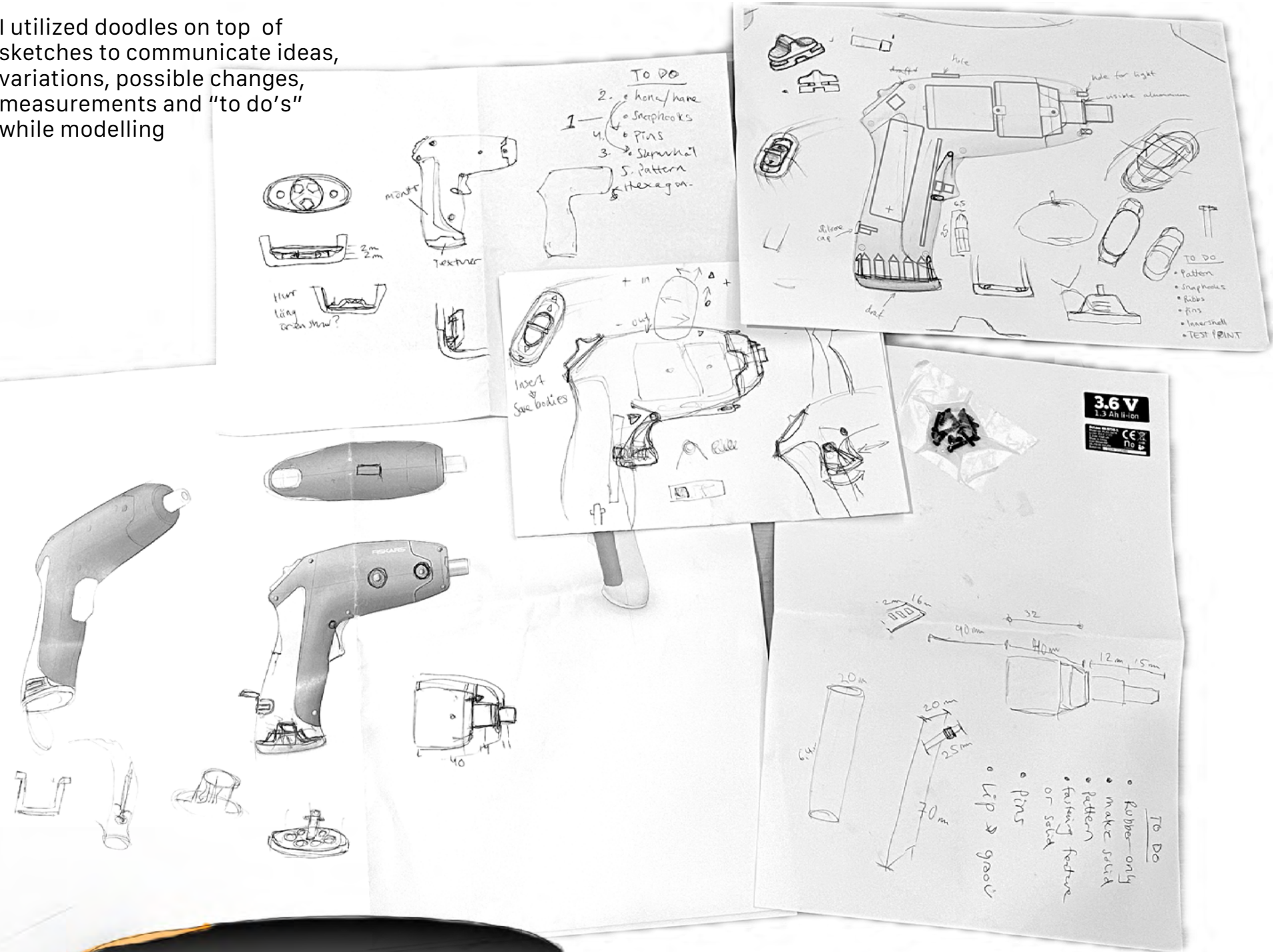



# IT STARTED OF GREAT...





# PROCESS

SOLID WORKS MODELLING, PRODUCTION ANALYSIS, ELECTRONICS, TESTING & TWEAKING

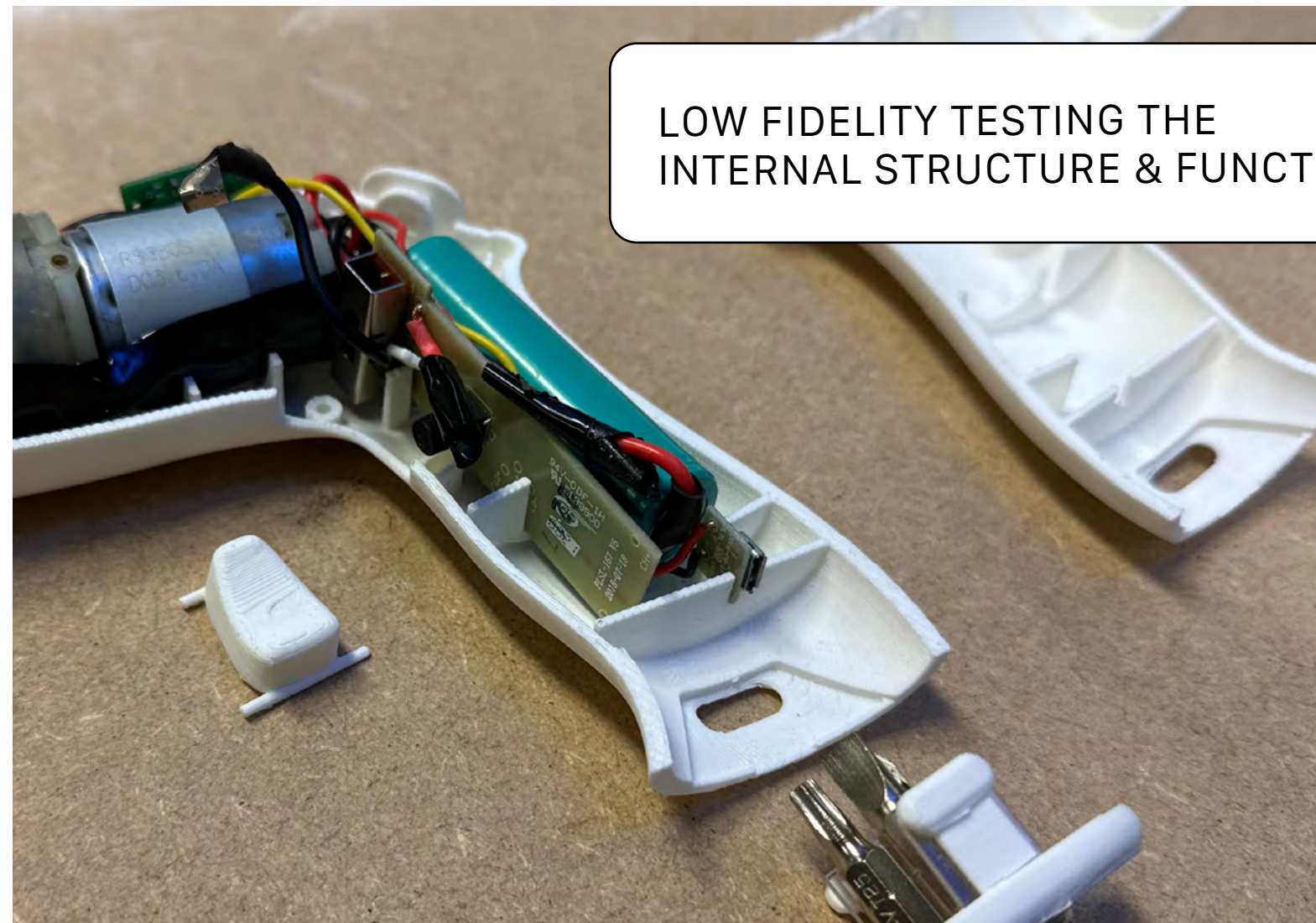
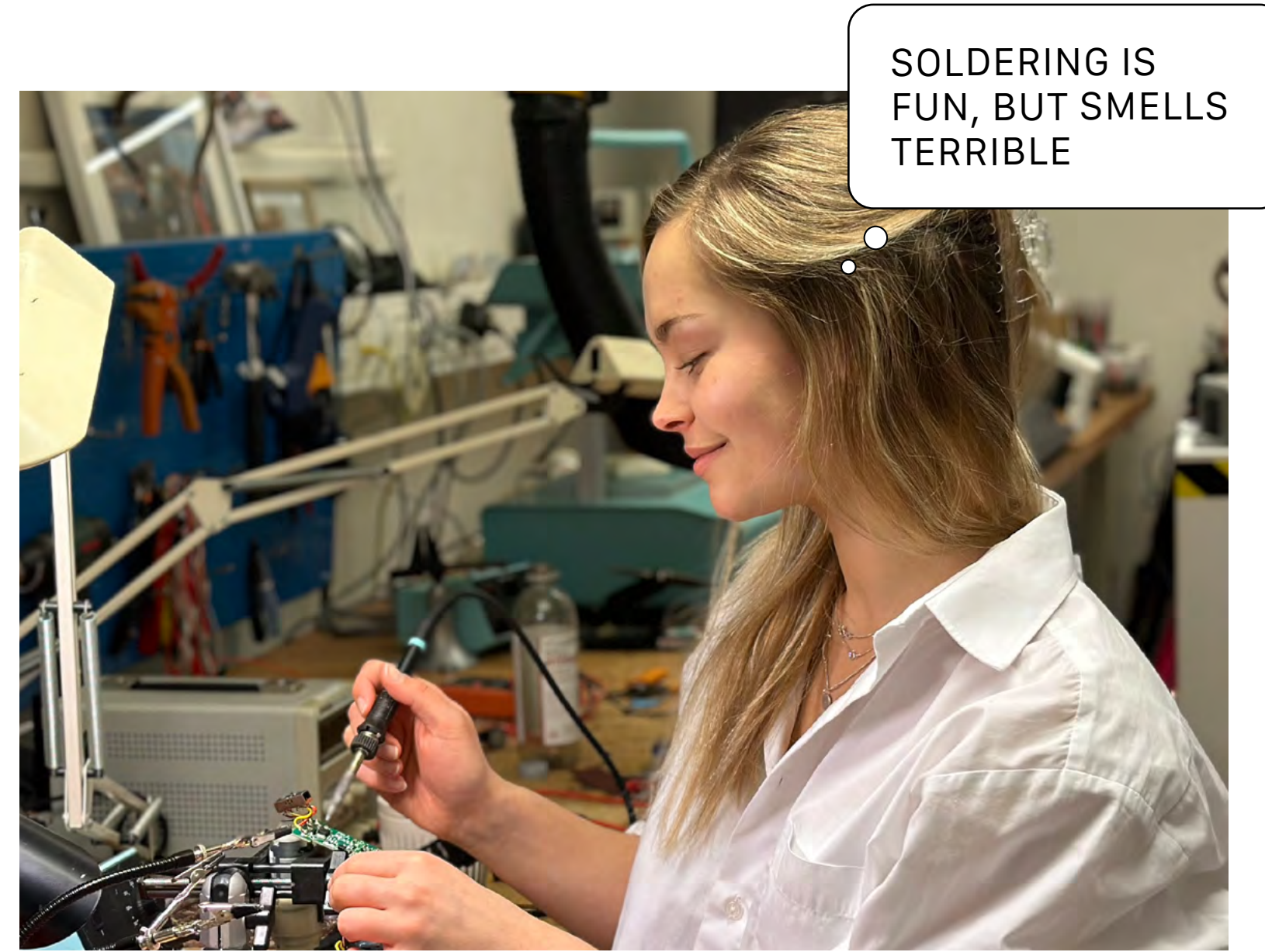
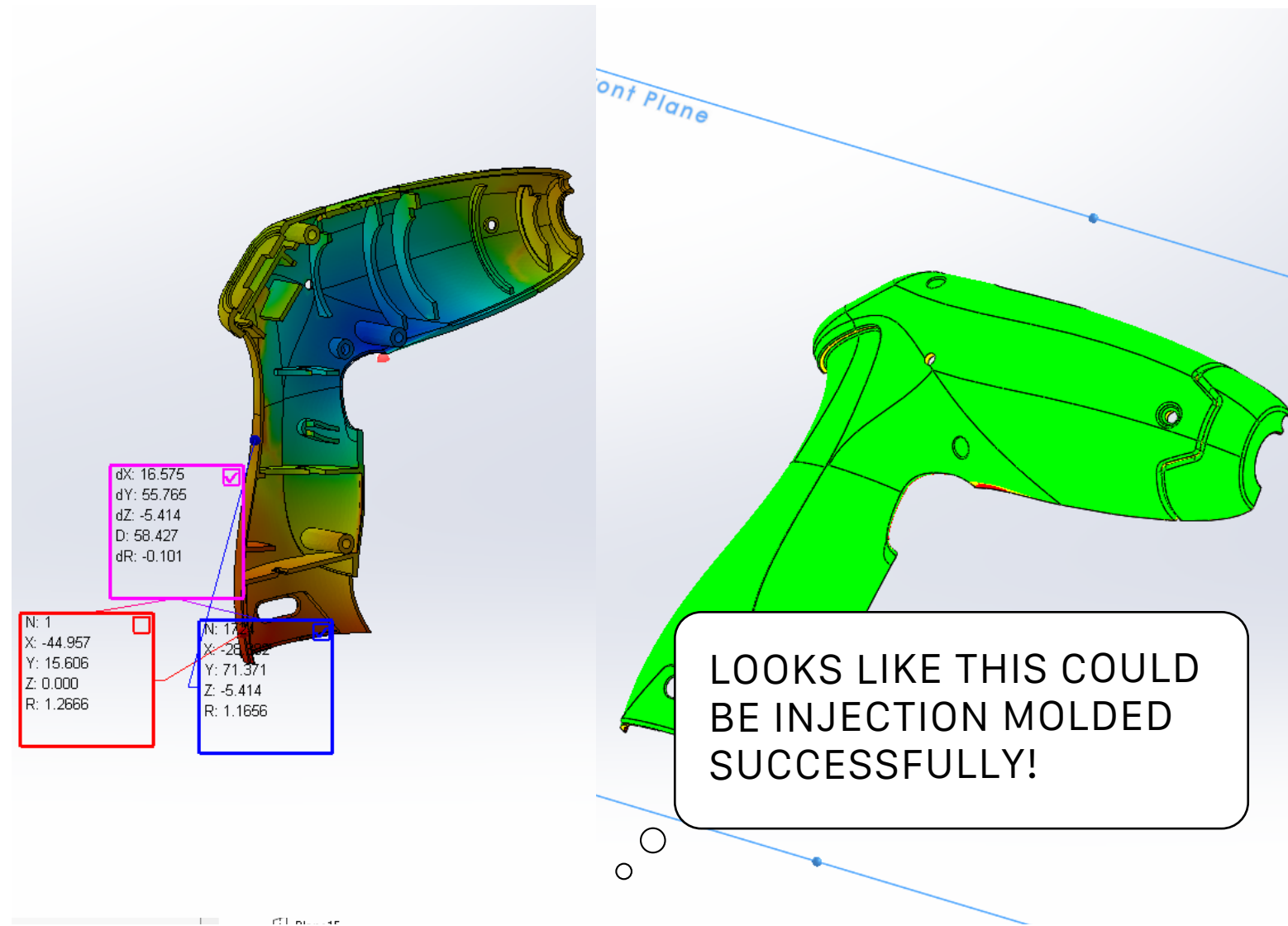
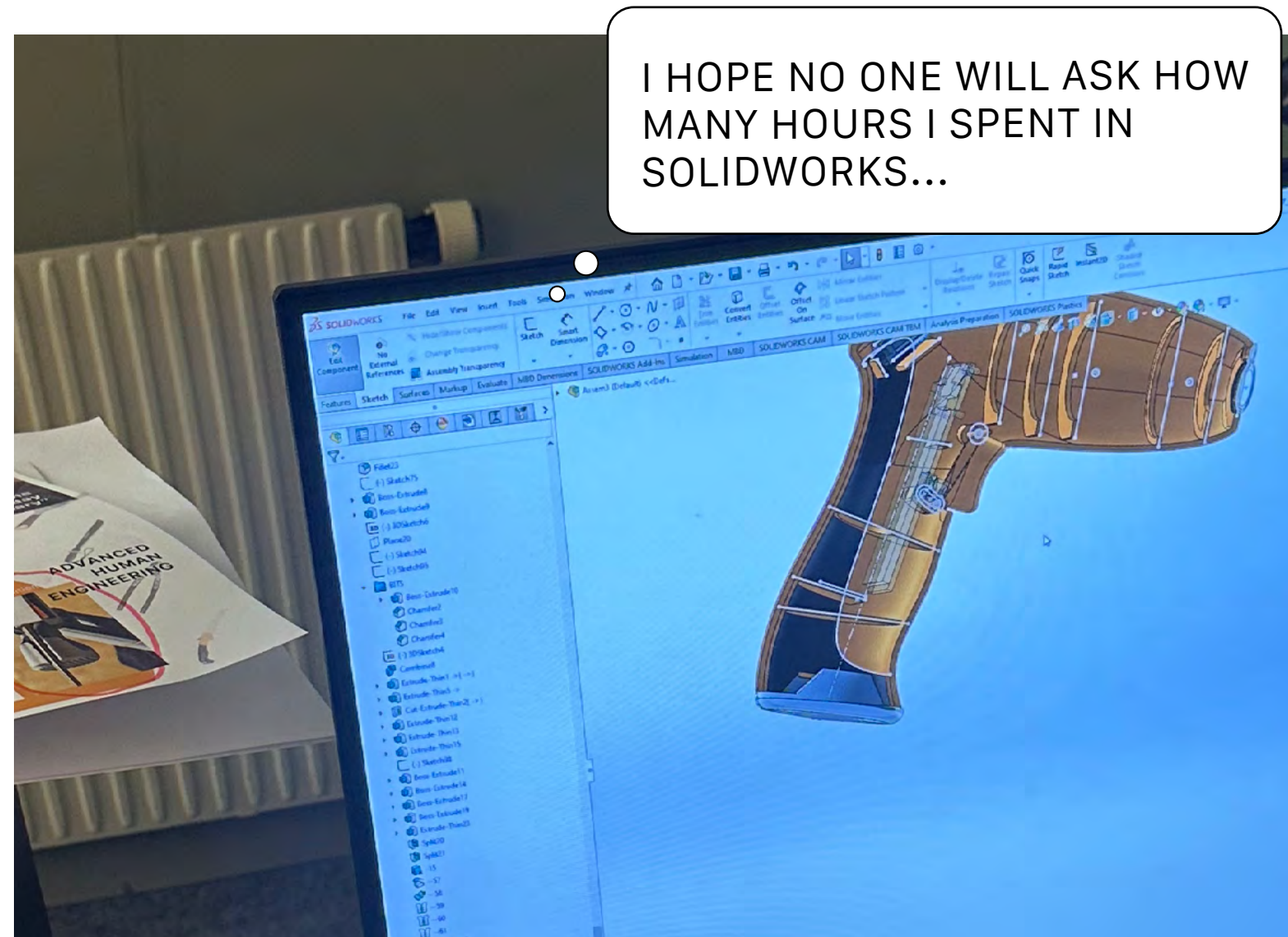



# FINAL PRINT

PRINTED IN OBJET30 IN A MIX OF TRANSPARENT & RUBBER





# FINAL PROTOTYPE



Easy access to your 3 most used bits by a snap-lock



The bits sits sturdy in the caps rubber part



Ready to screw!





...IT WORKED!



# FEATURES



**Charging port**  
Hidden under cap  
protected from dirt

**Mini flash-light**  
Visability in all environments

**Lights**  
Battery status indicator

**Switch**  
Intuitive & accessible  
with one hand

**Curved**  
Comfortable & natural grip

**Trigger**  
Soft rotating motion

**Storage**  
3 most used bits

**Soft touch**  
Rubber with debossed pattern



# REFURBISHED 01

How it could be resold after being given a second life by a Fiskars authorized store



Remove before use

Permanent ring ensuring quality

Silver screw to enhance the "eye"



Gives the experience of 'new' old



# DESIGNED FROM INSIDE AND OUT





# PARTS OVERVIEW



Inside right 2K shell



Outside left 2K shell

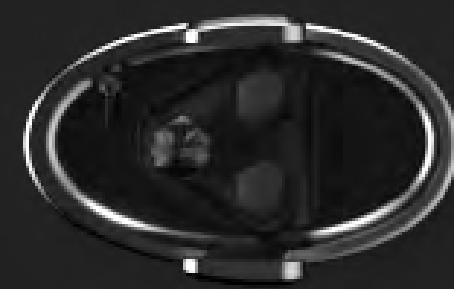

Bottom cap with rubber holder for 3 bits



Button



Switch



Refurbishment certification ring



"New" refurbished quality tag







# FISKARS®

Ergonomic design

Durable materials

Designed to be refurbished





*Learnings*

- Final sketches
- 3D modelling
- Collaborating with surface modellers & designing for production

# GARDENING TOOL

The client Wolf-Garten requested an extension to their e-multi-star system garden tool. I contributed with final product sketches & surface 3D modelling.



Picture: Wolf-garten.com



# FINAL CONCEPT

Final design alternations, sketches & CAD modelling in Rhino made by me

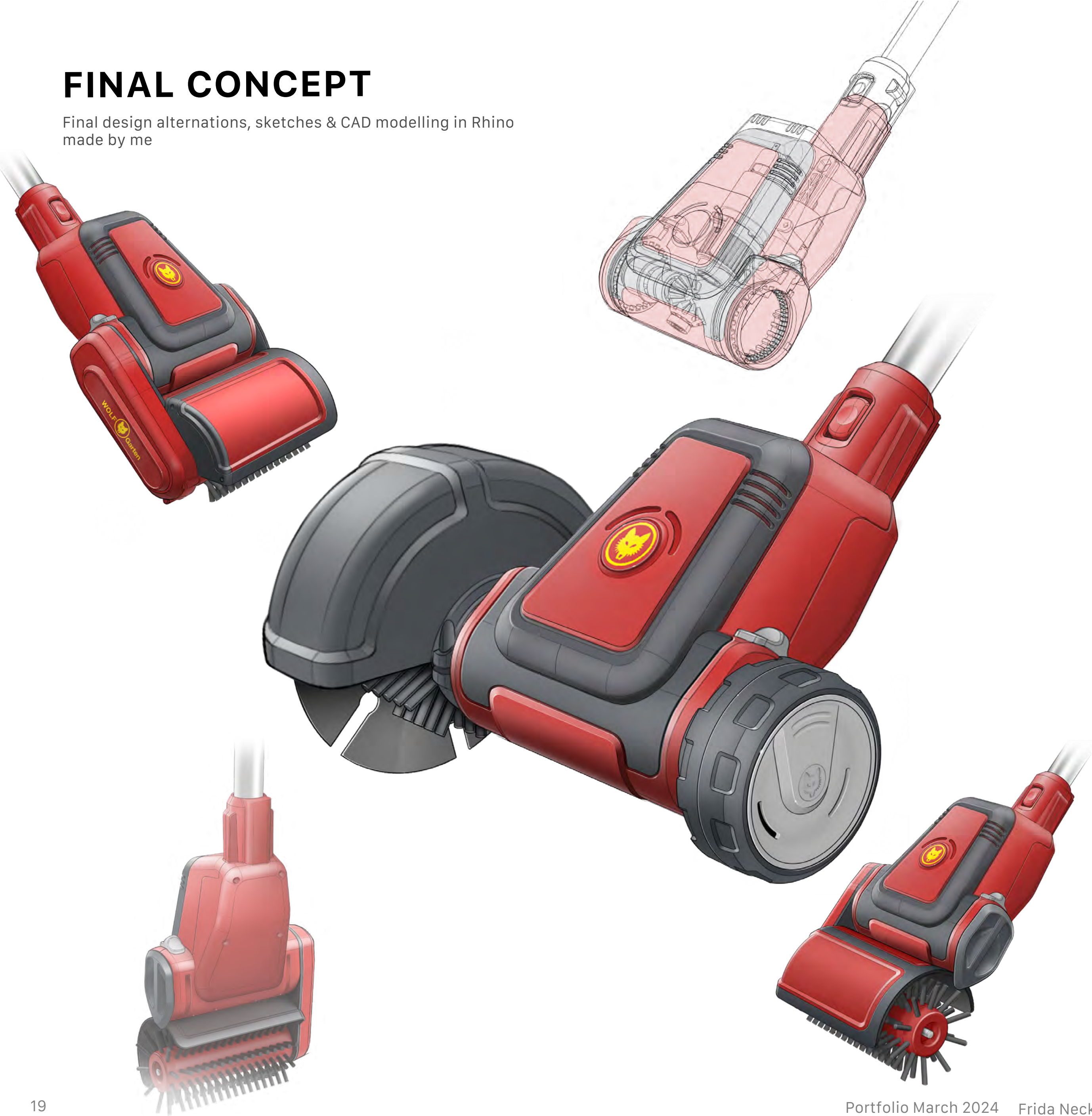

# FINAL PRODUCT



Picture: Wolf-garten.com

Status: Successfully launched 2024. Produced, sold and available in stores internationally



Learnings

- Trend analysis
- Ideation
- Rapid sketching
- Client meetings

# KITCHEN CONCEPT

SieMatic Kitchen requested a new luxury kitchen where I participated in the start of the project with focus on research, trend analysis, ideation & initial concepts. In parallel, we made smaller changes to an already released kitchen design.

tatic designstudio X SieMatic

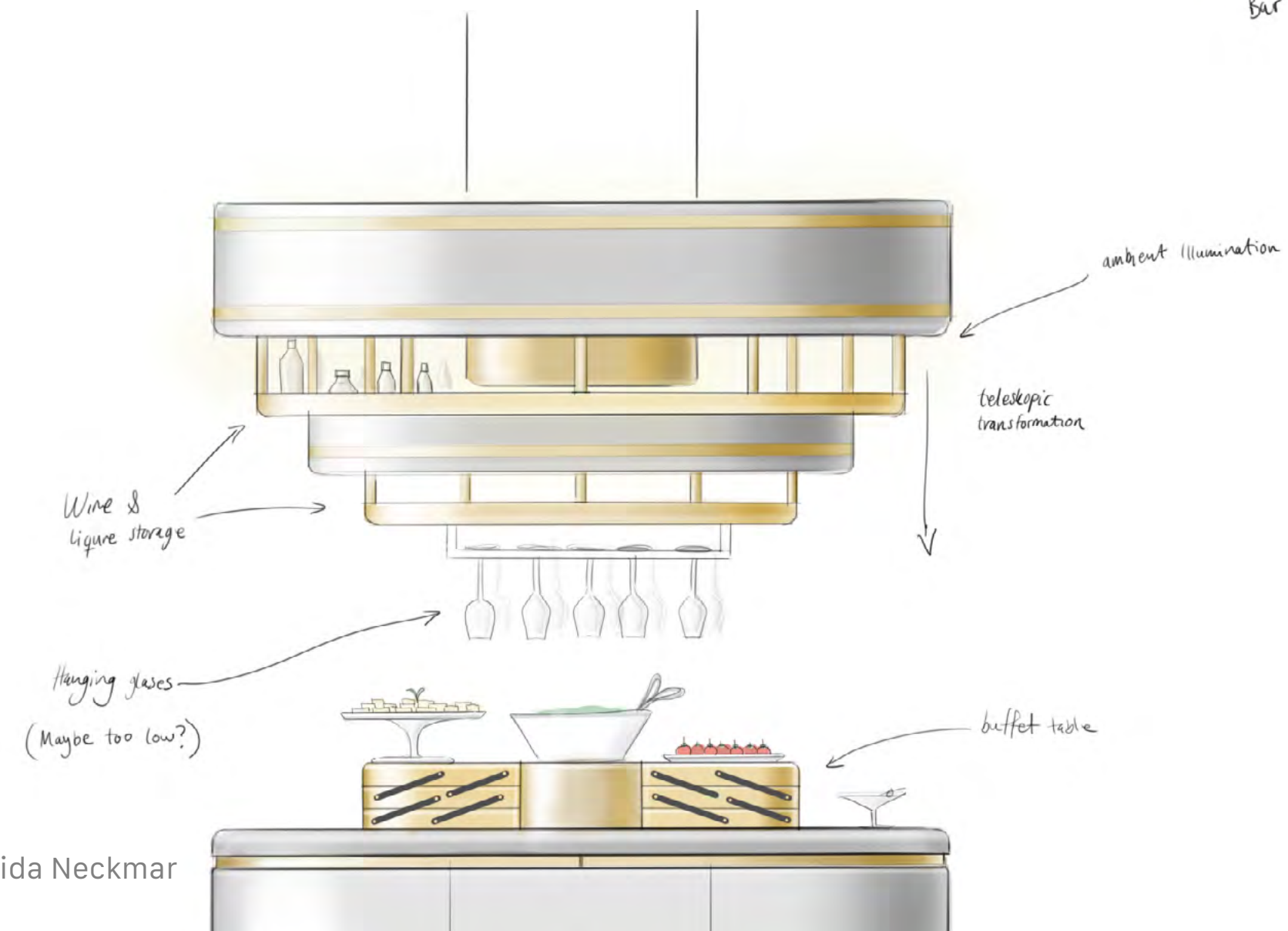
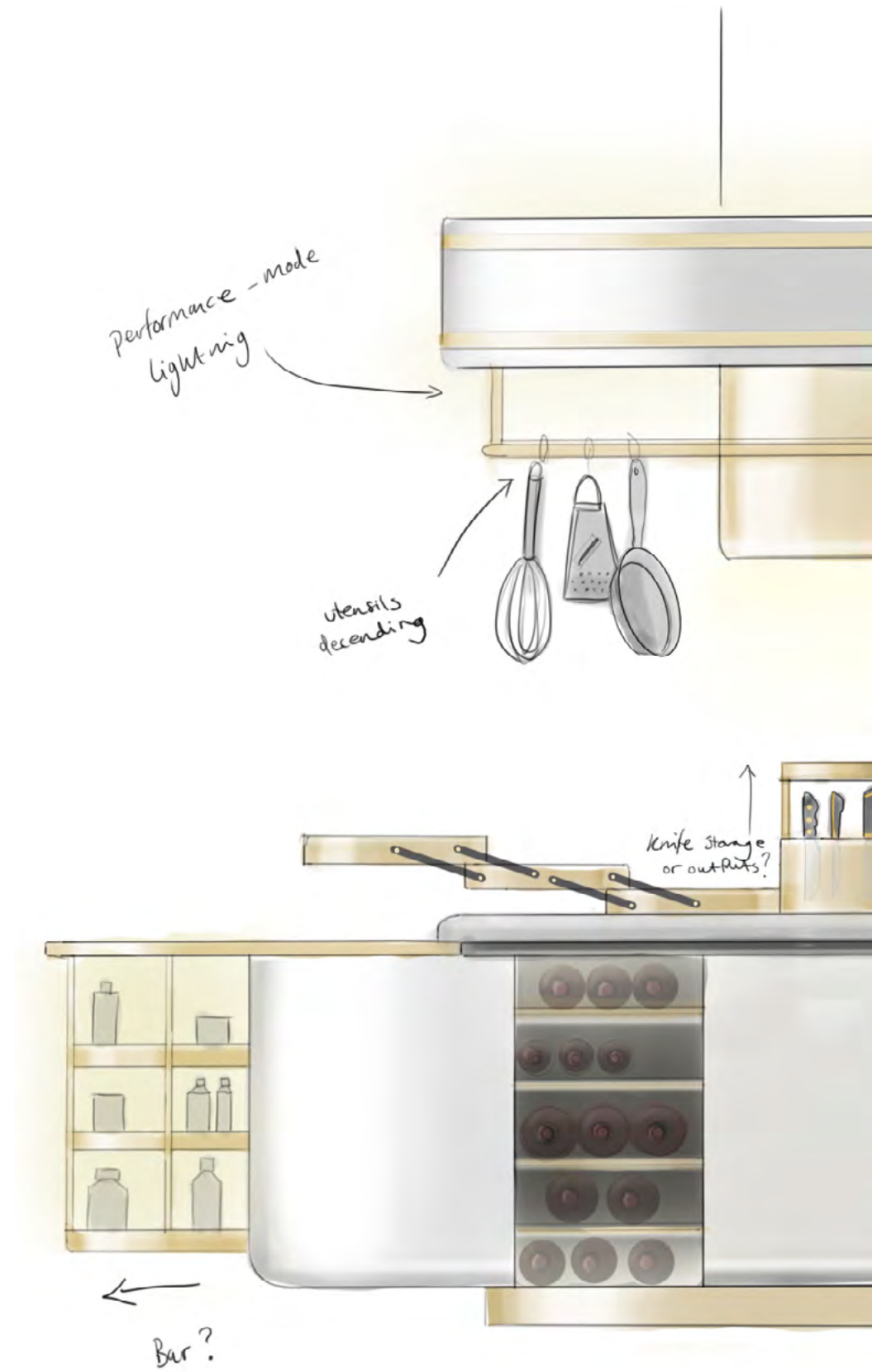



# CONCEPT: TRANSFORMATION

Living kitchens is on the rise and people desire open layouts, with a kitchen island that takes the center stage. Imagine a luxury kitchen island that transforms to your different needs; creative cooking, calm everyday & social bar area for when you have guests.



Calm before the storm

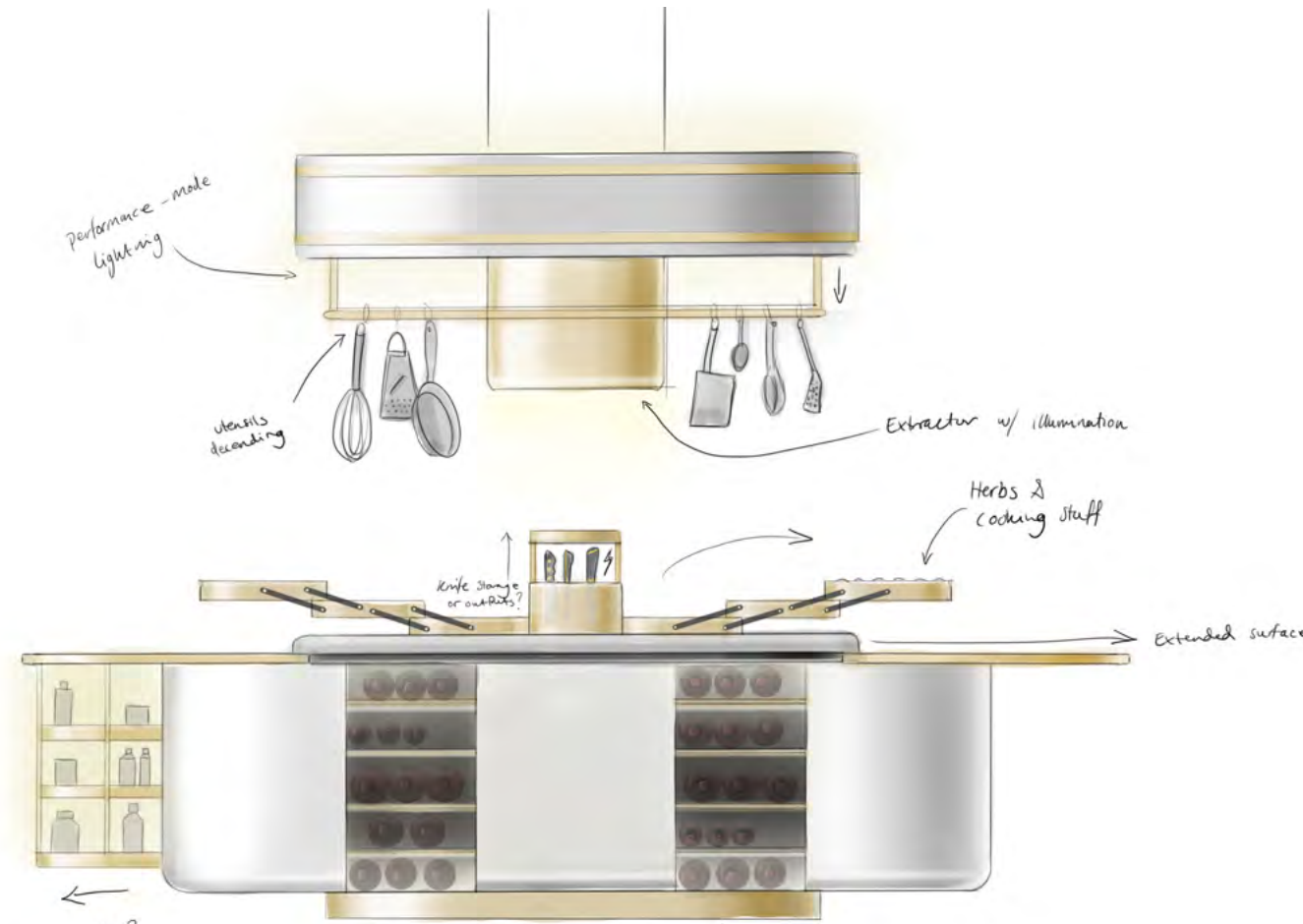

Creative Battlefield

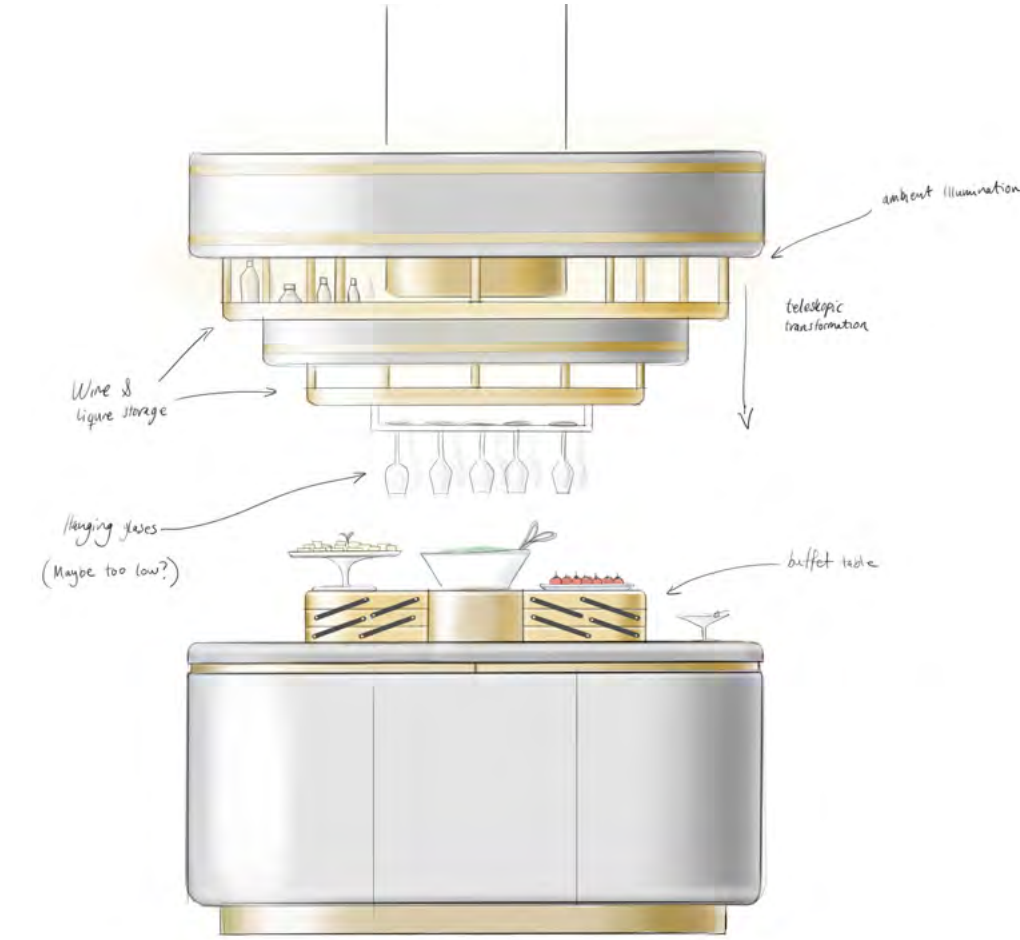

Social Bar





# MONDIAL: REFINING

In parallel as we made the new luxury concept, we analysed Siematics Mondial kitchen, showcased at Milan design week 2023, to be improved prior to launch. Me and my team made suggestions of changes in terms of dimensions, harmony, handles, CMF & functionality.





## GROUP PROJECT 2023

Frida Neckmar, Mårten Malmnäs,  
Julius Bahl

### Learnings

- Rapid mock-up
- Sketch video
- Trend research
- User-journey

# A U T O C A R E

In collaboration with Electrolux, we explored how garment care would look if the primary user was a domestic robot.



UMEÅ INSTITUTE  
OF DESIGN

X



Electrolux





# HOW WOULD OUR HOUSEHOLD APPLIANCES LOOK IF THEY WERE DESIGNED FOR MORE THAN JUST HUMANS?

As the population ages and more people live alone, imagining a future where the elderly can comfortably stay in their own homes with the help of household robots becomes increasingly realistic, especially with the next generation of home bots on our doorsteps. But, how would our household appliances look if they were designed for more than just humans?



**+100%**

People over 60 years is expected to double globally by 2050

**40.8 %**

...of women over 65 years in Europe live alone

**1/5**

...of all women over 65 years had service 31 Oct 2021



COLLECTING



TRANSPORTING



OPERATING



WASHING





# FROM SKETCHES



## COMPACT WASHER

Made for the smaller home

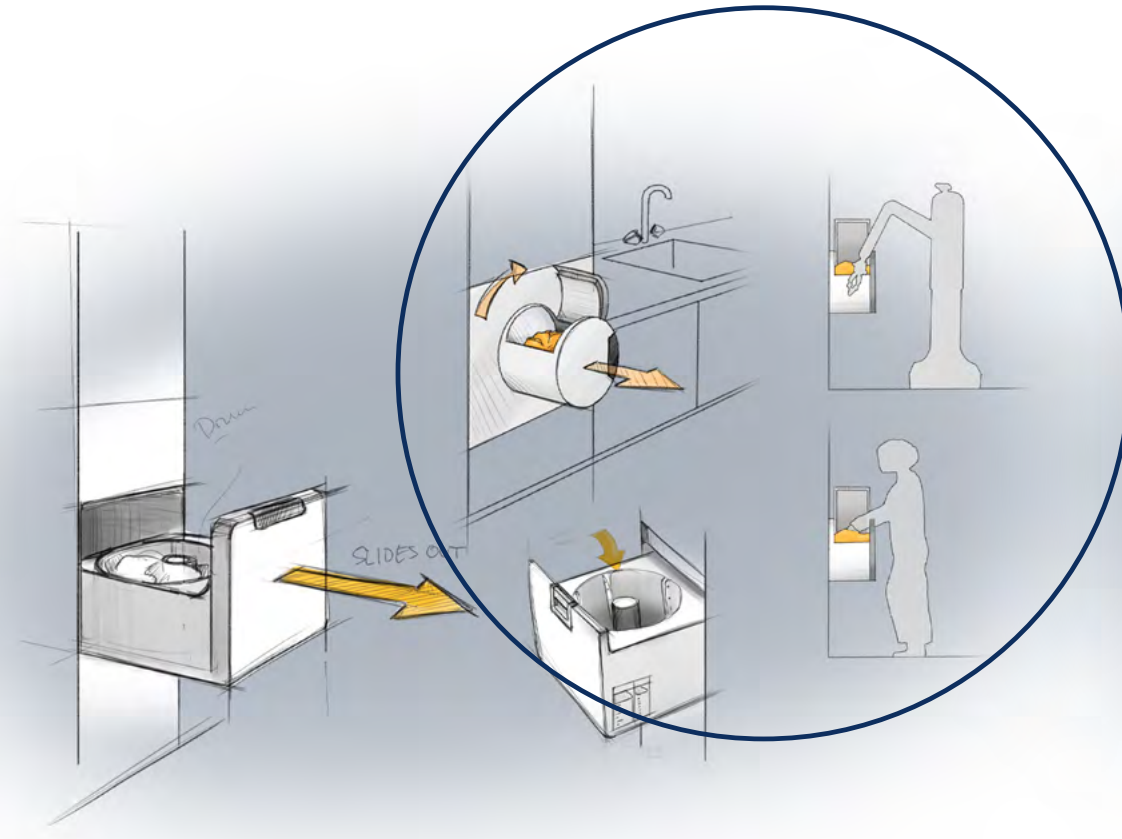

## ERGONOMIC WASHER

Fits the physique of the elderly

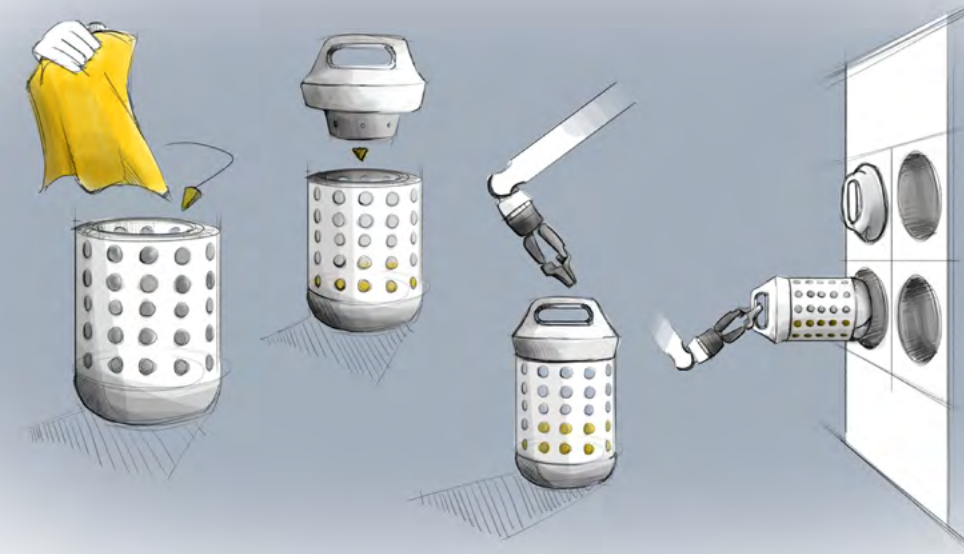

## LAUNDRY BAG SYSTEM

From the laundry bag to the machine



# TO SKETCH VIDEOS



DROP OFF



PICK UP

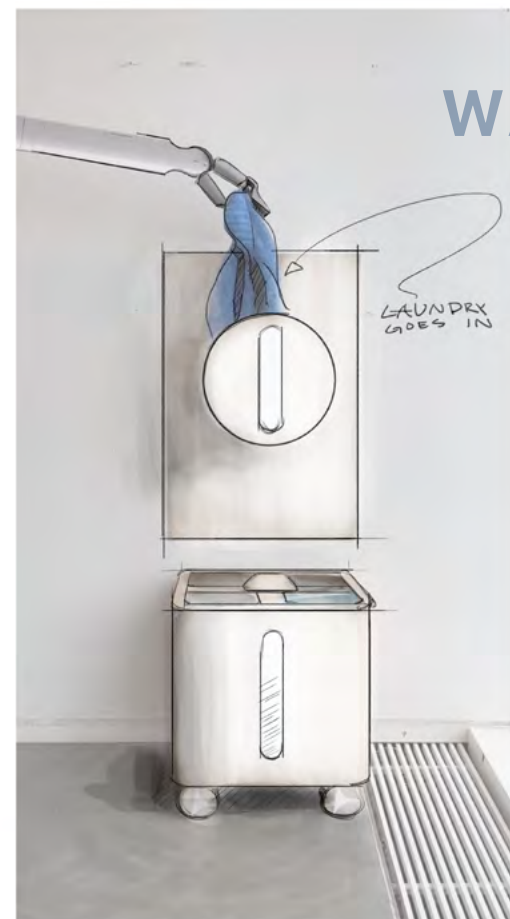

LOAD



EMPTY



PICK UP

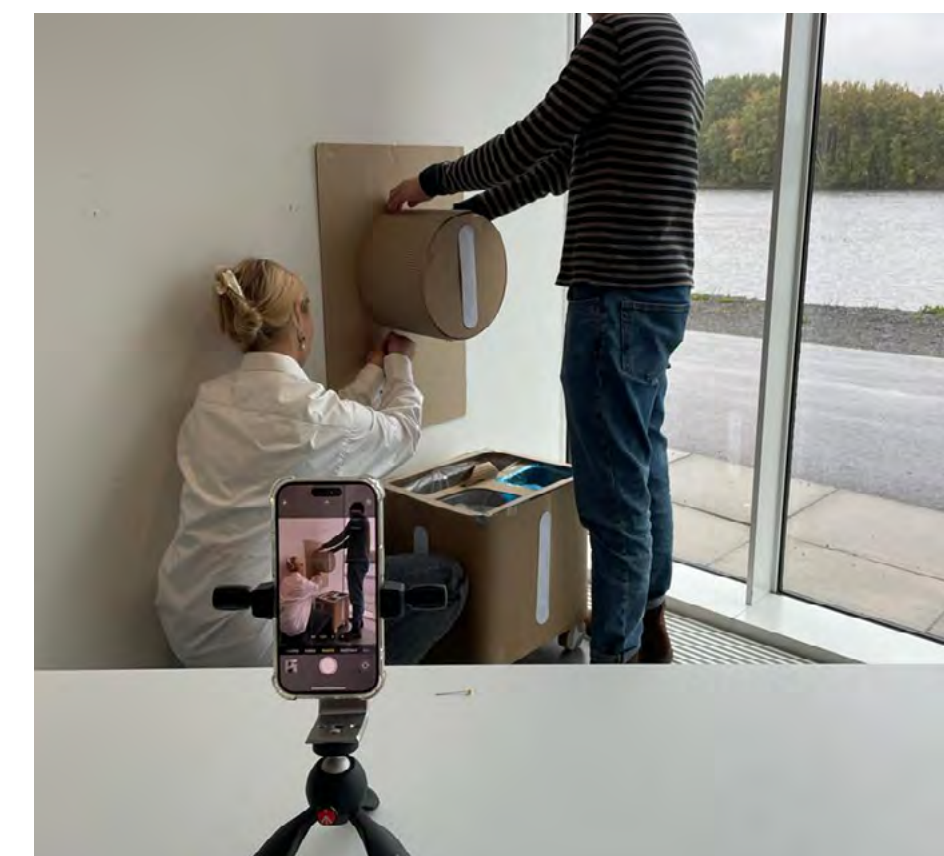



# USER JOURNEY & USAGE

Bot Handy does a daily check of various home appliances.



Taking the laundry out of the compartment.



Loading the machine.



Checking the laundry basket.

"This one looks full"

Transporting to the washer.



Washing...

Done!



Approaching...

Waking up the machine.



Picking up the fresh laundry.

Helping Kerstin hang up the clothes.





# THE BASKET

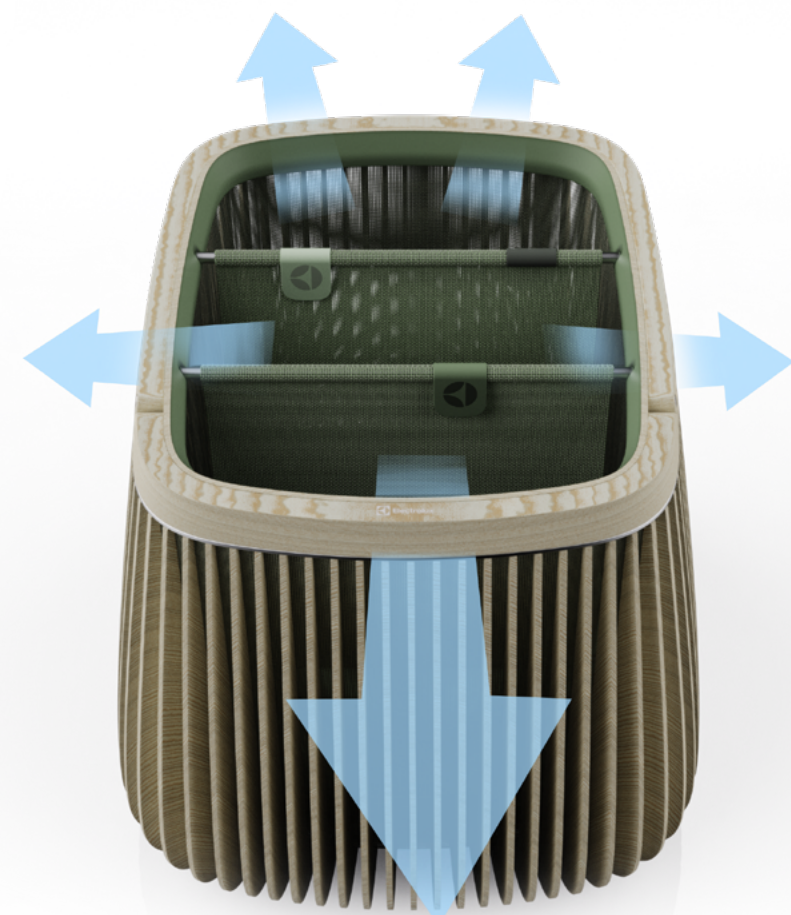

Ventilation

RFID-tag



Easy sorting for human and robot





# THE WASHER

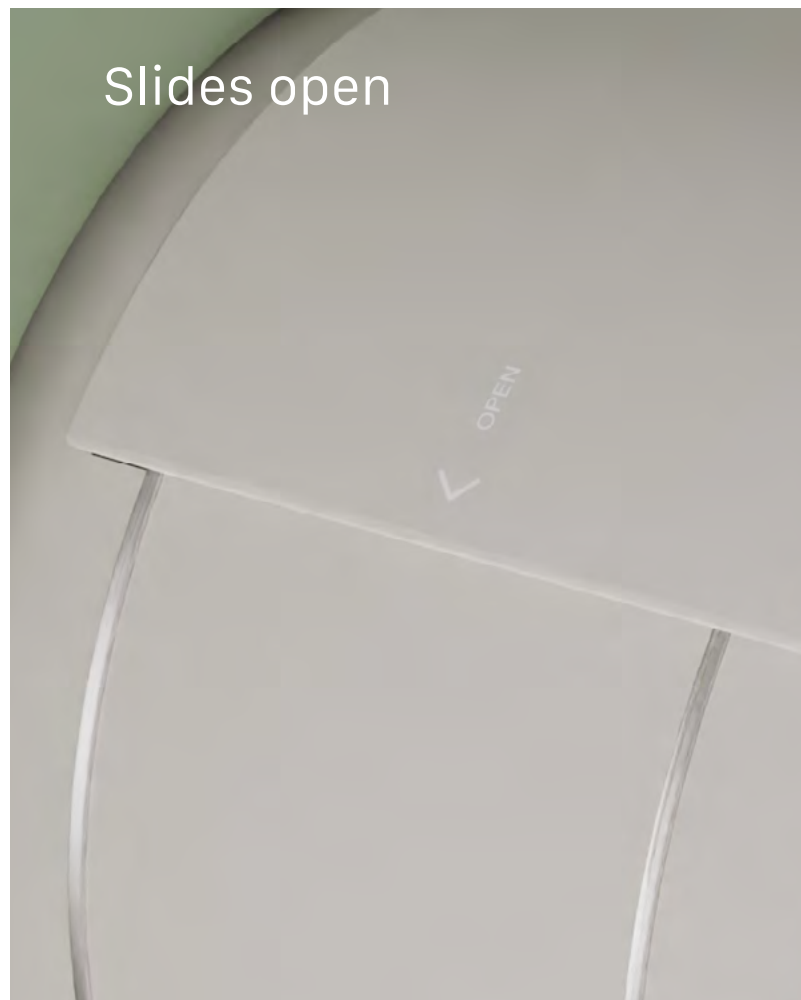

Laundry catcher



In collaboration with  Electrolux

# AutoCare

AutoCare is a compact laundry system consisting of a small washing machine and smart laundry basket, optimised for domestic robots & elderly people



AutoCare Washer

AutoCare Basket



Learnings

- User-centered design
- Interview techniques
- UXI, Figma
- System-design

# FREYA

In collaboration with Einride, I looked in to the future of logistics.  
How might we improve the flexible work environment of electric truckdrivers?



UMEÅ INSTITUTE  
OF DESIGN



einride





# DRIVER SHORTAGE

# 3.0 m

Over 3.0 million truck driver jobs are unfilled globally 2023 according to IRU

Imagine yourself working at an office where you have to change desk several times a day

You arrive to your workspace after a colleague, and it looks like this:



Thats a reality for many truck drivers today, and is one of the acknowledged problems I have targeted in this project, to improve their work environment



# I LOOKED INTO THE DRIVERS OFFICE

...LITERALLY



I organized additional interviews with different drivers to gain insight in what problems they were facing during their daily operations, with focus on the swapping of vehicle with co-workers.



# HOW MIGHT WE IMPROVE THE FLEXIBLE WORK ENVIRONMENT FOR TOMORROW'S TRUCK DRIVERS?

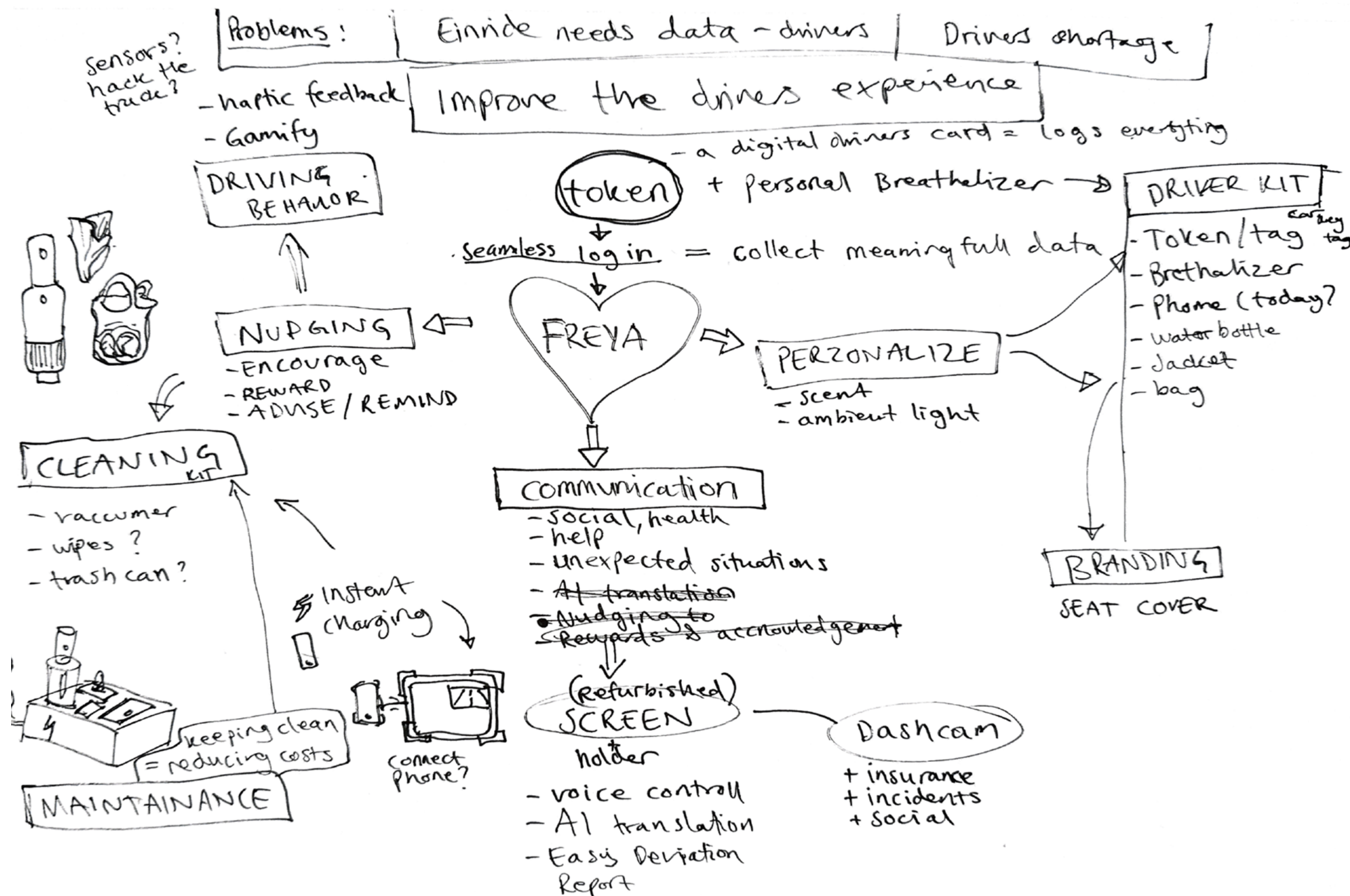

## HOW I MAPPED THE DRIVERS USER JOURNEY

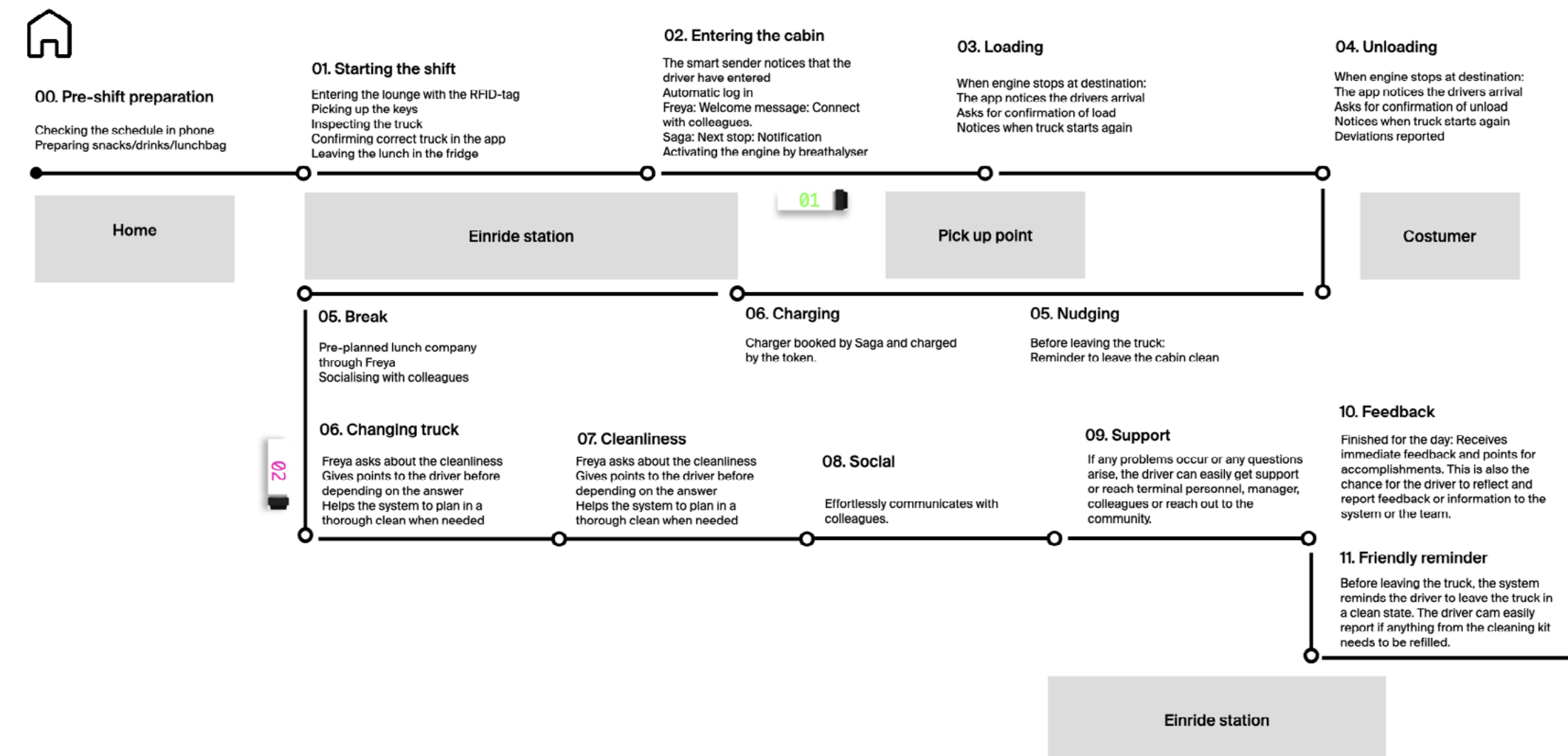



# FREYA

In response to the global driver shortage, Freya—a part of Einride's fleet manager Saga—enhances truck drivers' work environment. Combining software and hardware, it tackles daily cabin changes and acts as an on-boarding kit for carriers transitioning to electrified shipments. As a digital assistant, Freya promotes collaboration, cleanliness, responsibility, and community through nudging, gamification, and a social platform. The system features a retrofittable screen as its hub, housing the digital driver assistant and an induction charger. The 'token,' a multi-functional breathalyzer, serves as an access key, ensuring a seamless, personalized experience with enhanced hygiene.

Addressing the daily challenges of changing cabins, Freya envisions a future where every truck driver experiences an empowered, connected, and valued journey on the road.

## PRODUCT OVERVIEW

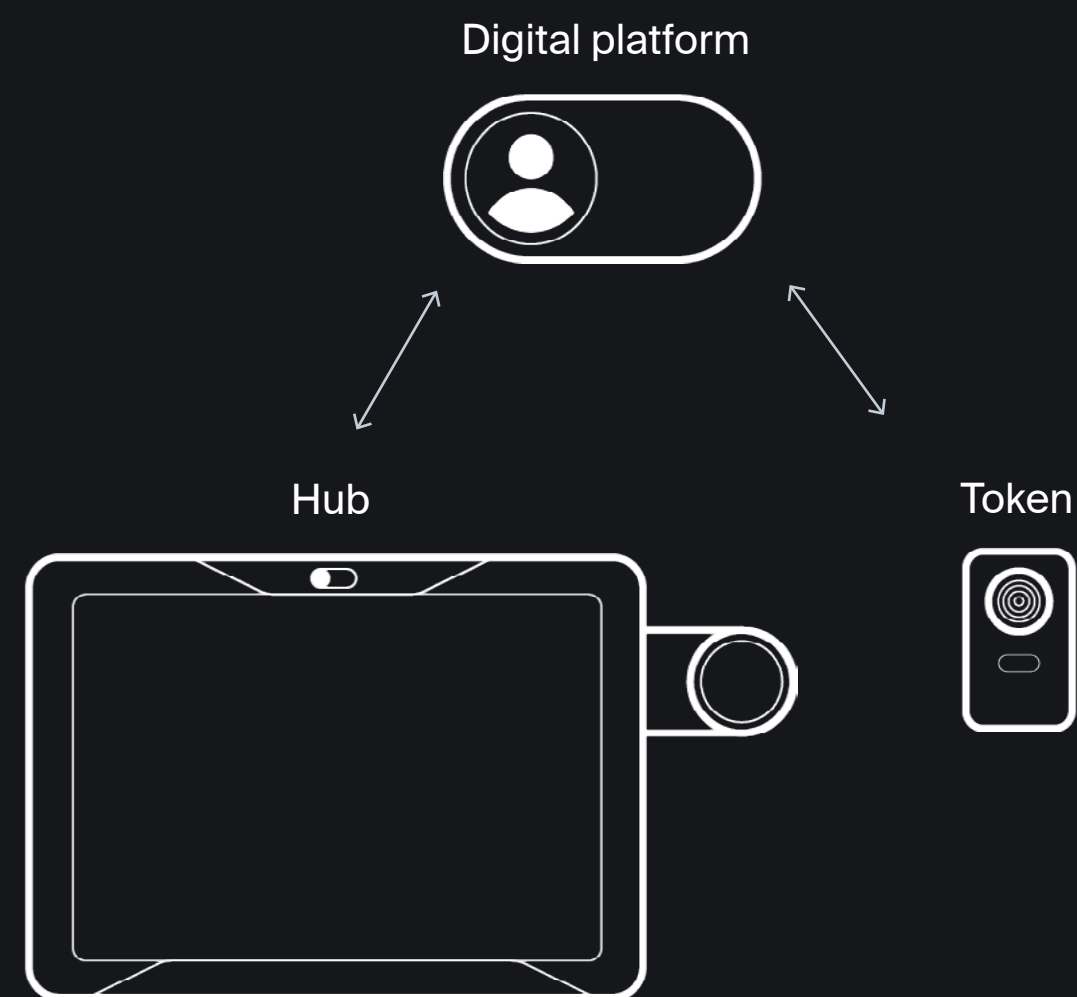



Einride Saga

empowered by

Einride Freya

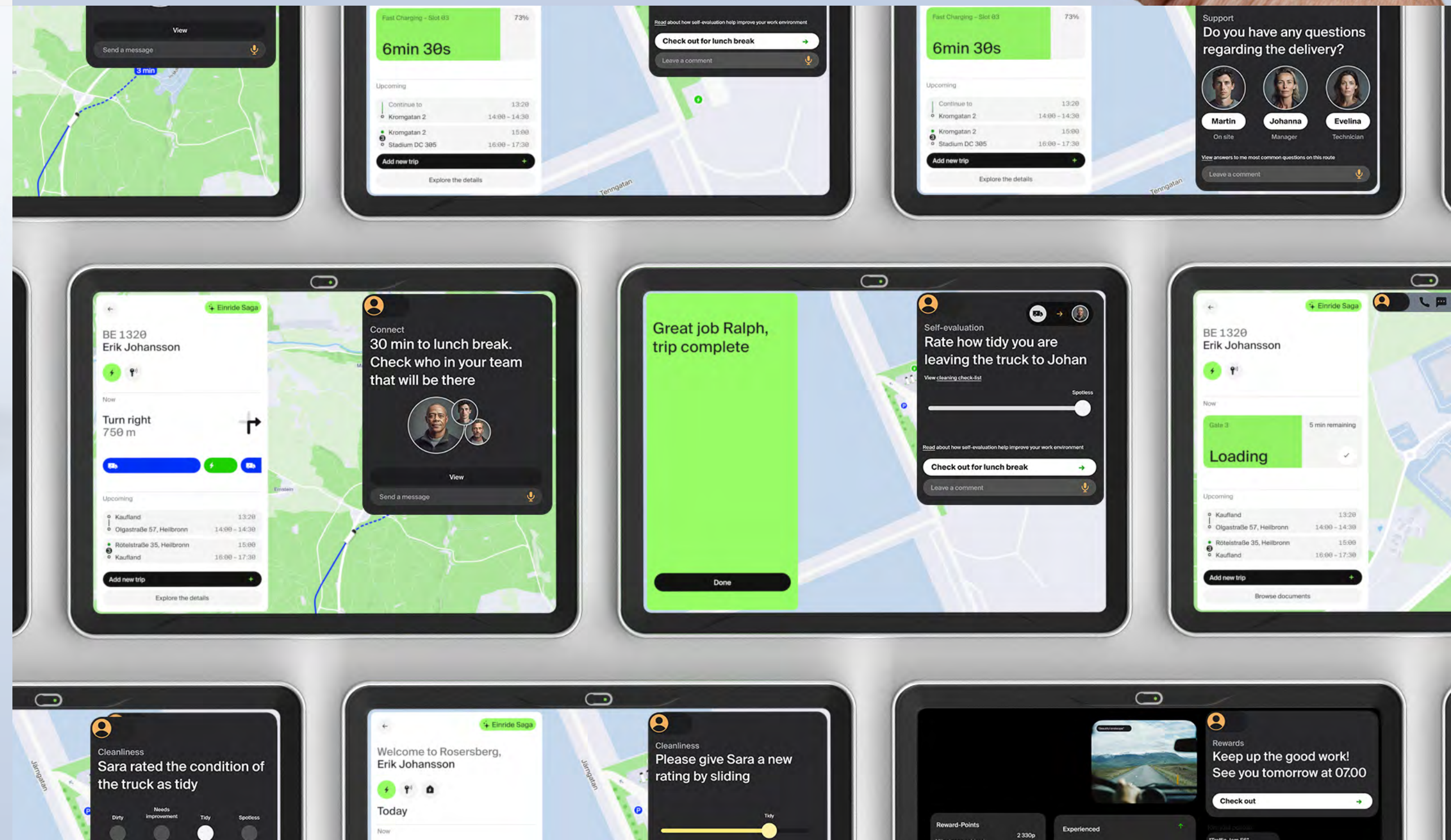
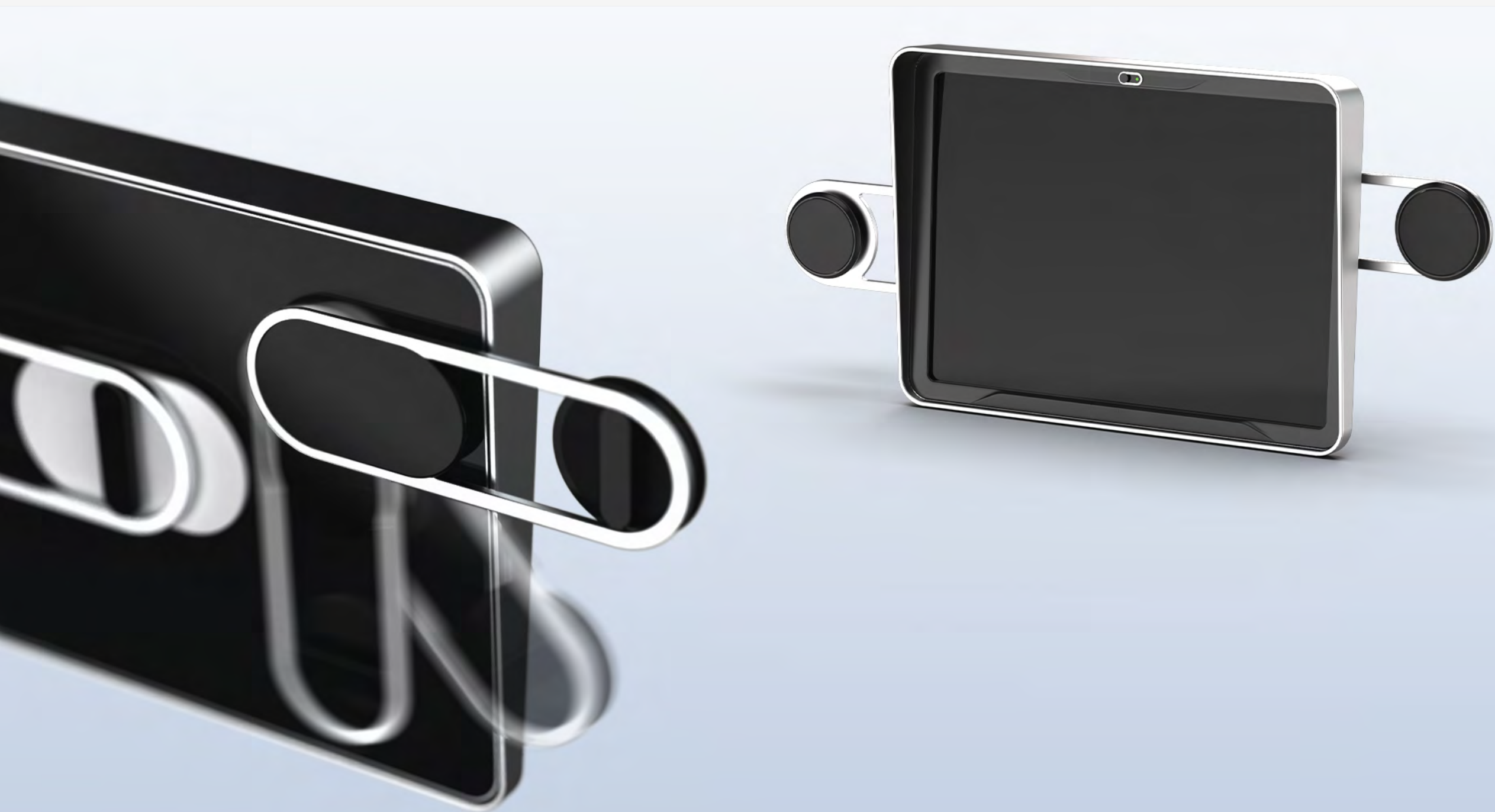





In collaboration with  einride



- Design Process
- Design management
- Material exploration

# HOLD MY FLOWERS

How can precious fresh cut flowers selfsustainably be arranged to be fully showcased and make them come into their own?



X

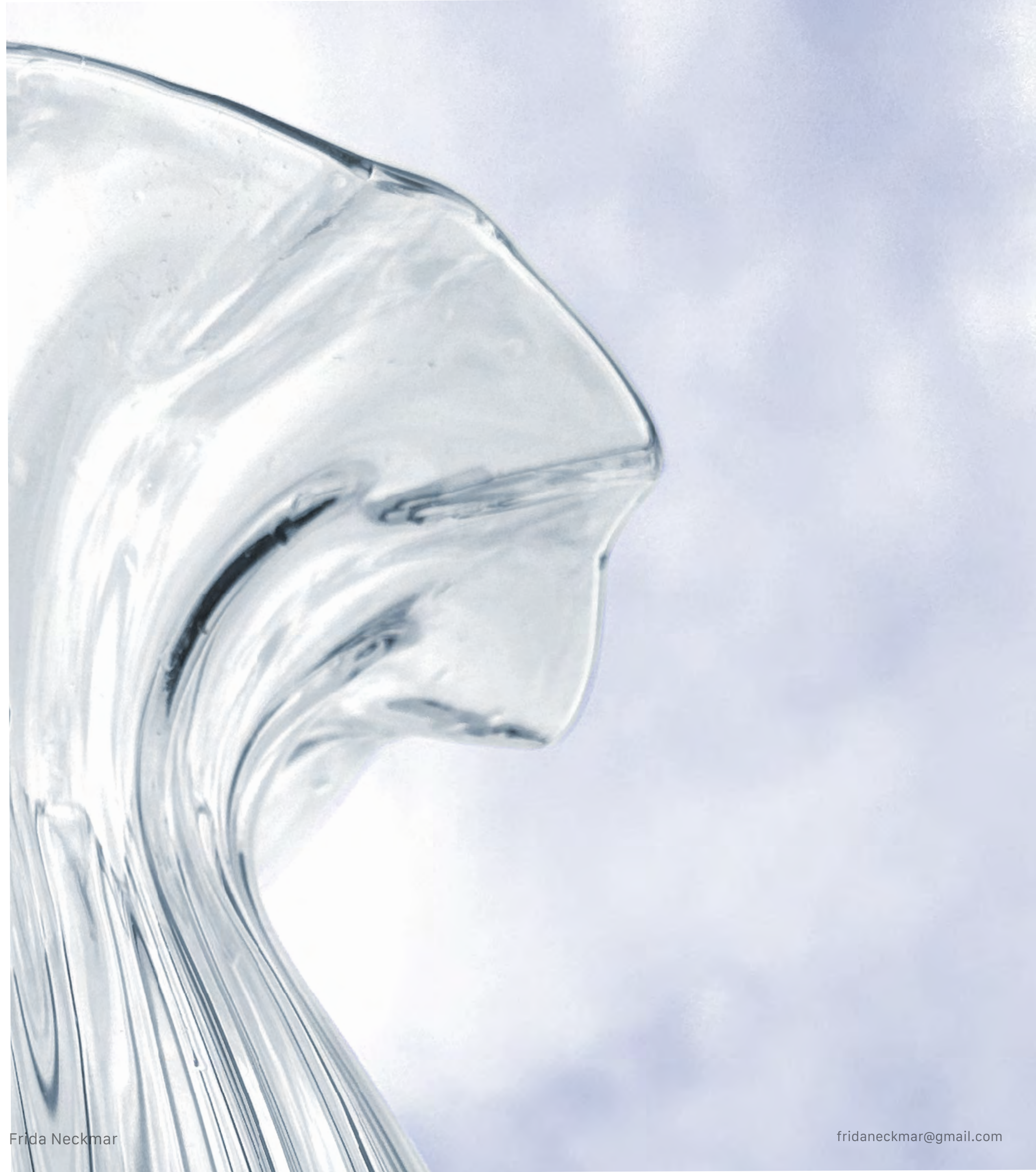



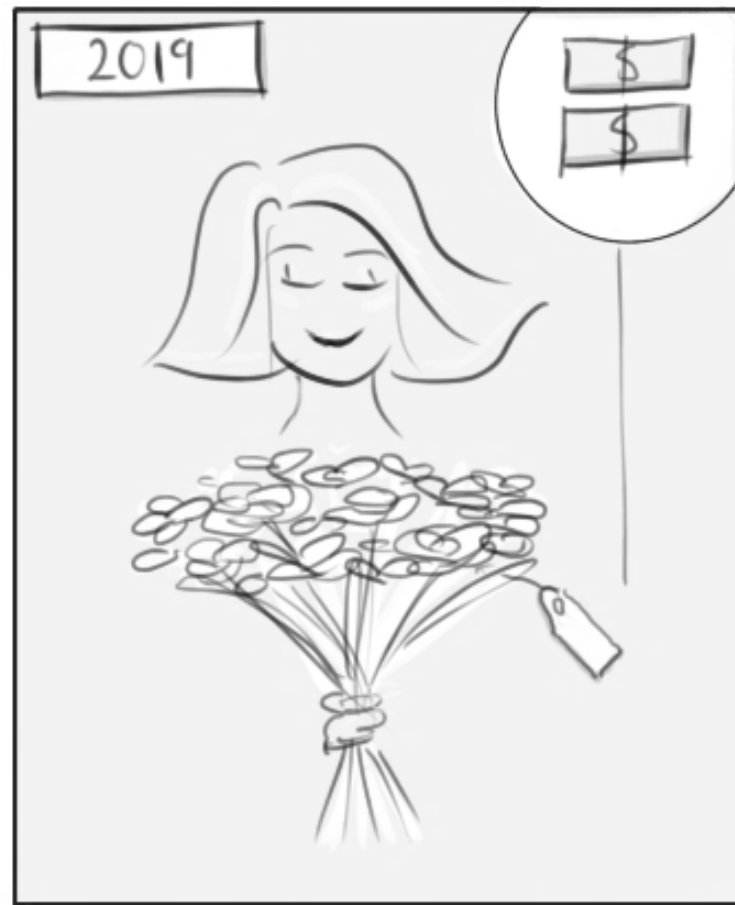

THE RISING PRICES OF FRESH CUT FLOWERS CREATE A FAVORABLE MARKET OPPORTUNITY FOR PRODUCTS THAT ENHANCE THEIR LIFESPAN AND VISUAL APPEAL





# IMPROVEMENTS

Following valuable feedback from both my academic mentors and peers, I conducted further research to enhance the functionality and manufacturing process of my design prototypes before final production.

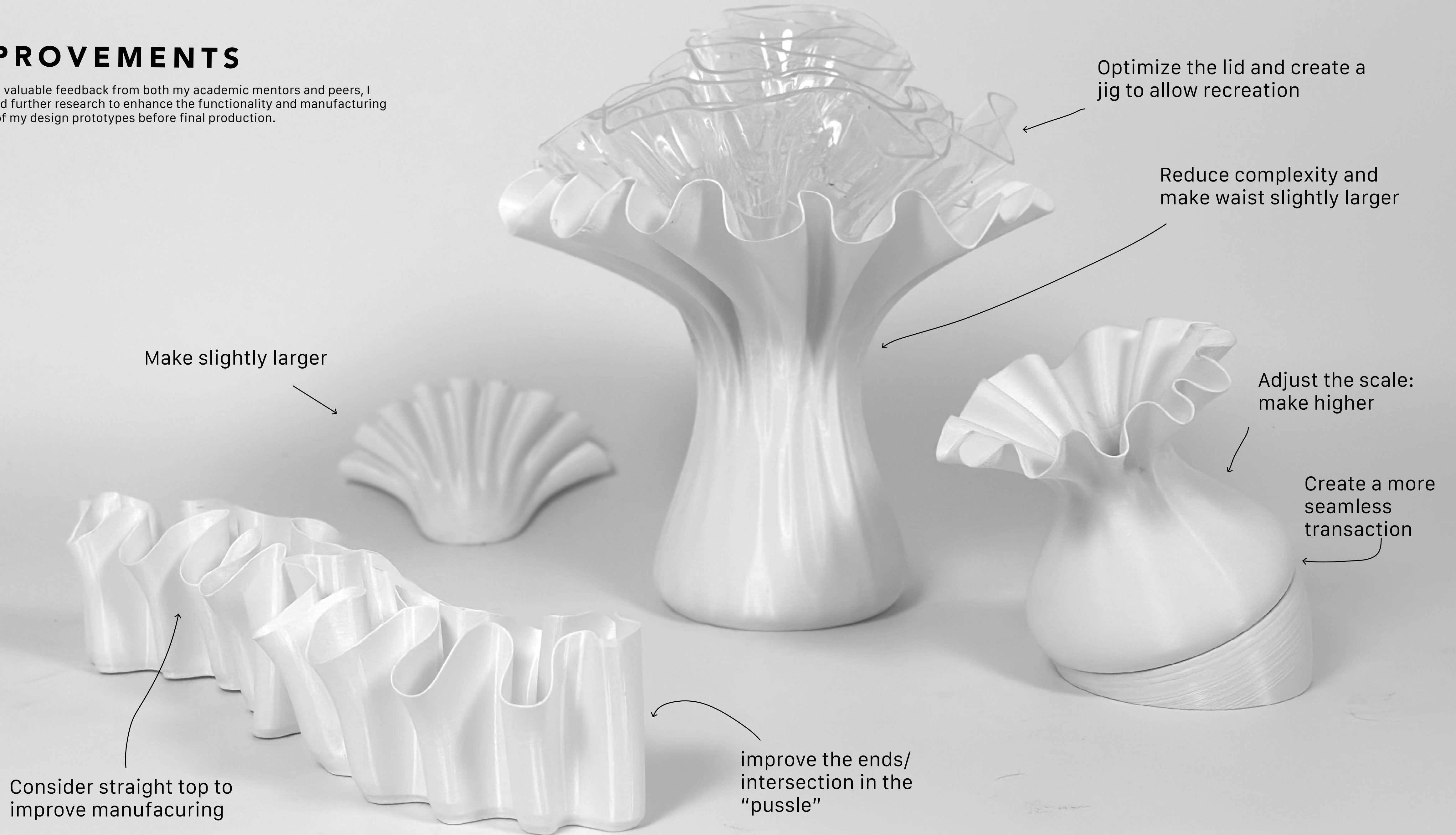



# MATERIAL EXPLORATION





# EXHIBITION





# BEO BOTANIC

The brief was to design a cordless garden tool with a given technical underlays for a brand of choice. During this project we worked close with Tatic Design studio who provided us with the task, tech packs and valuable industry feedback.

*Learnings*

- Brand Language
- Mood boards
- Target group
- Technical underlays





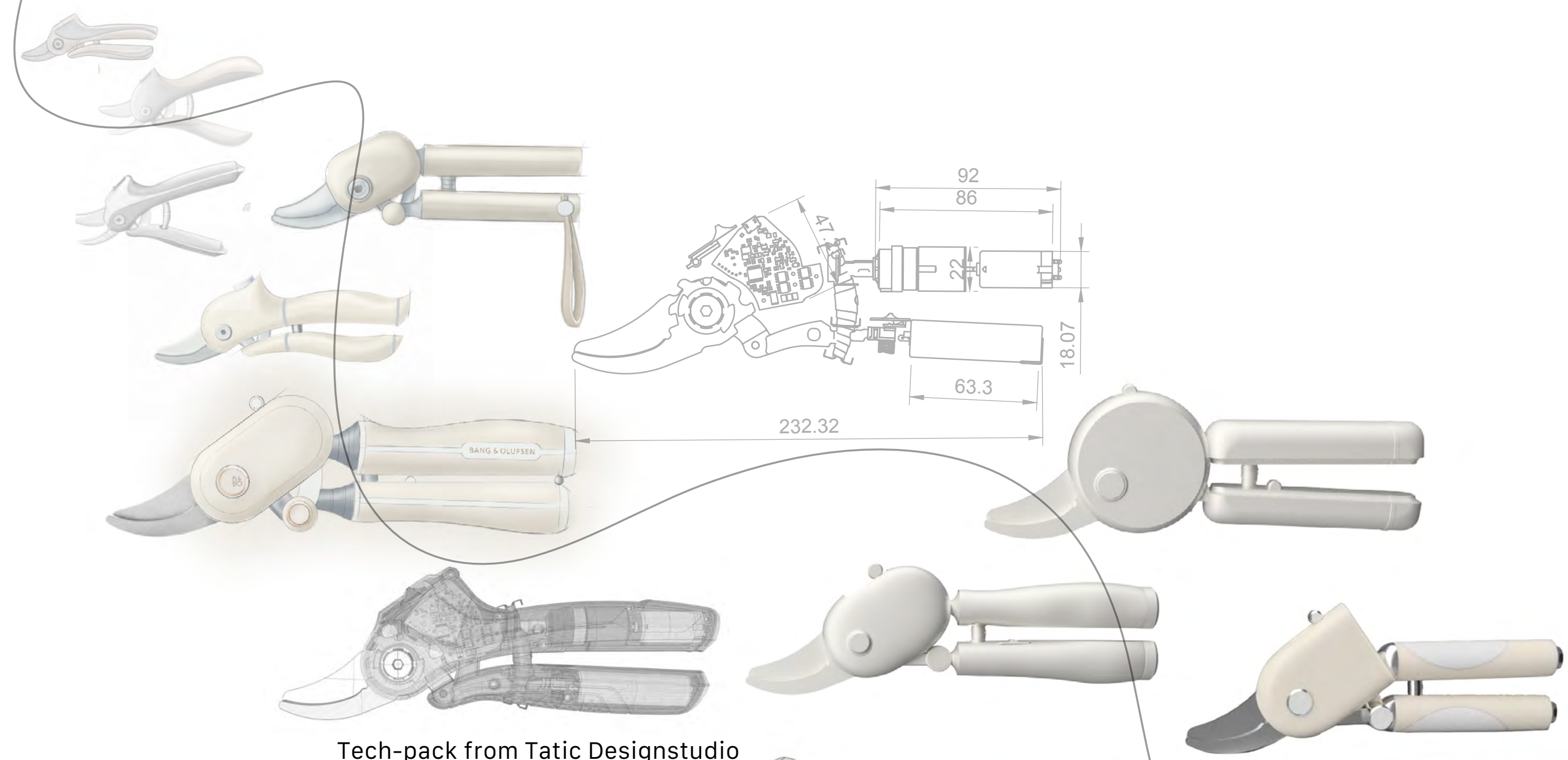

Functionality, ergonomics and form language was the focus, where the tech pack of all necessary components where the main restraining factor.

Tech-pack from Tatic Designstudio

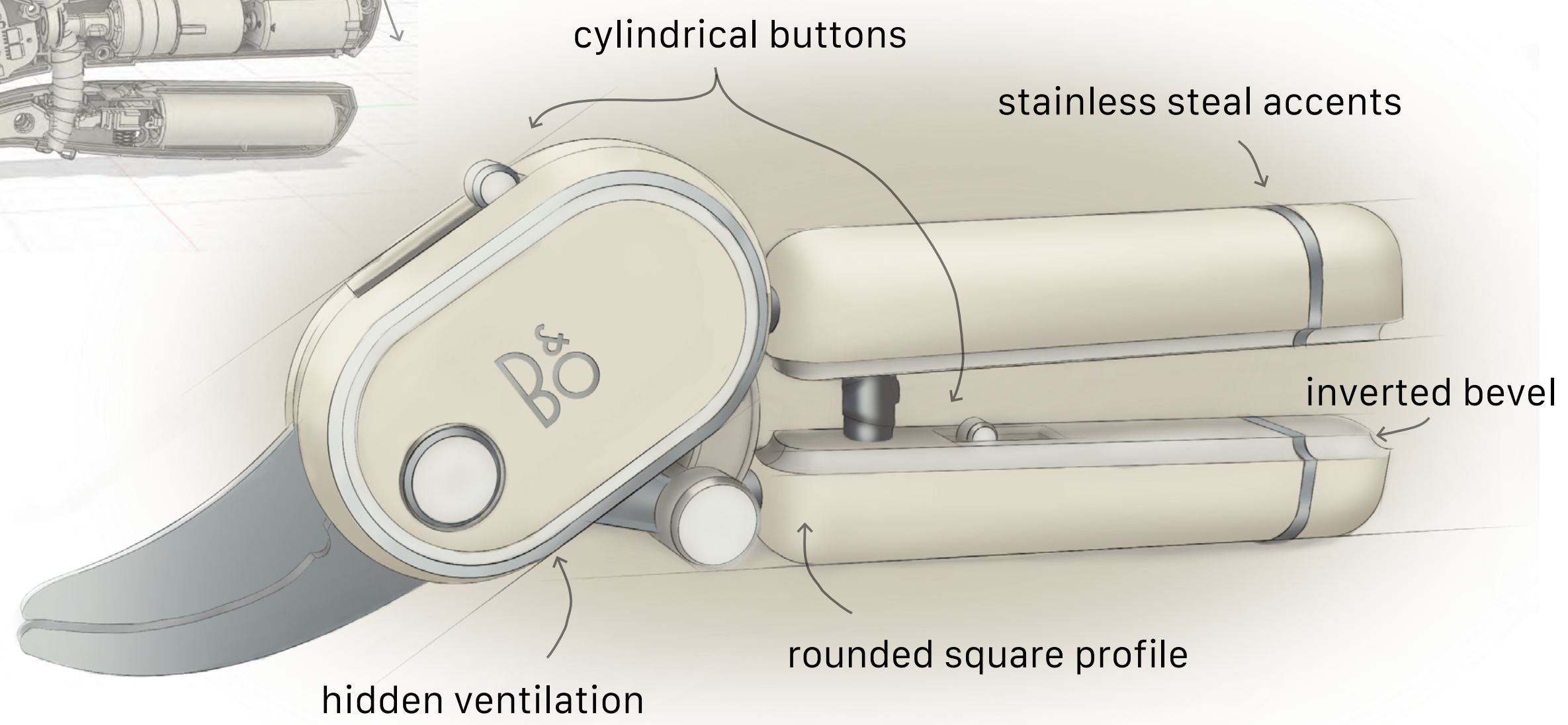
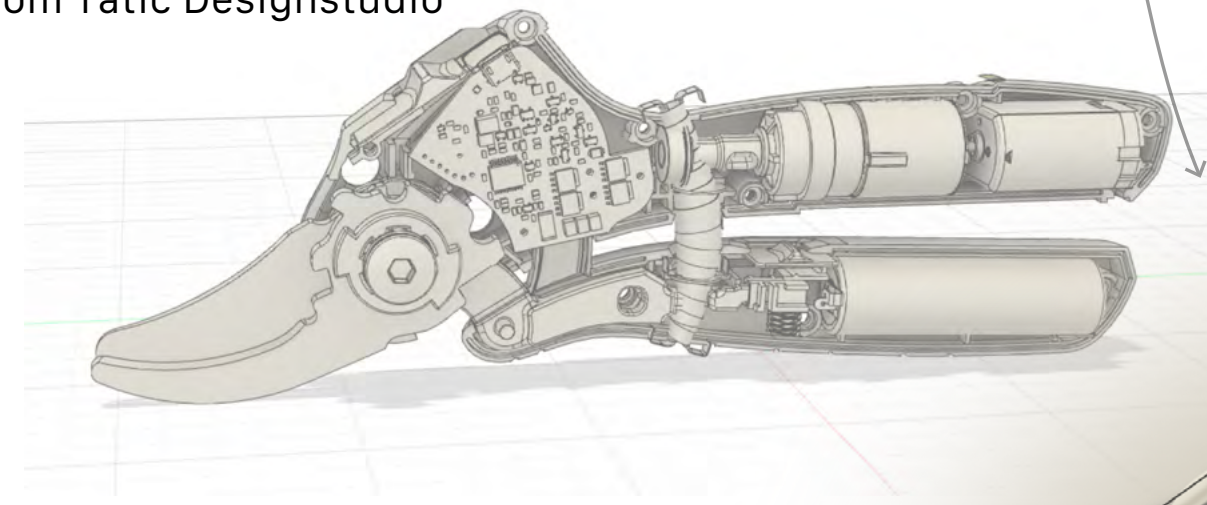

Most of the final decisions where based of ergonomic factors which where confirmed by clay model's and grip study. For example, I choose a rounded square profile instead of cylindrical on the handle to prevent slipping, but kept the lines straight to fit the ergonomic.





# BEO BOTANIC

"an electrical, cordless pruner, for  
both indoor and outdoor usage"



- Design Process
- Ergonomics

# HAND TOOL

The project WREB is a product of the course Design Methodology  
with the given task to design a handheld tool





# BACKGROUND

In today's modern, increasingly specialized society, work injuries are becoming more common. It's the second most common injury causing lost work days.

The performed movement used with regular brooms puts a lot of strain on the wrist.

**16.8**  
work days where  
lost due to hand  
and wrist injuries /  
per 10,000 full-time  
workers

- 2016 Bureau of Labor Statistics.

# IDEA

an ergonomic durable dustpan and broom set with relief for the wrist in the specific motion being used and the initial inspiration was a crutch.

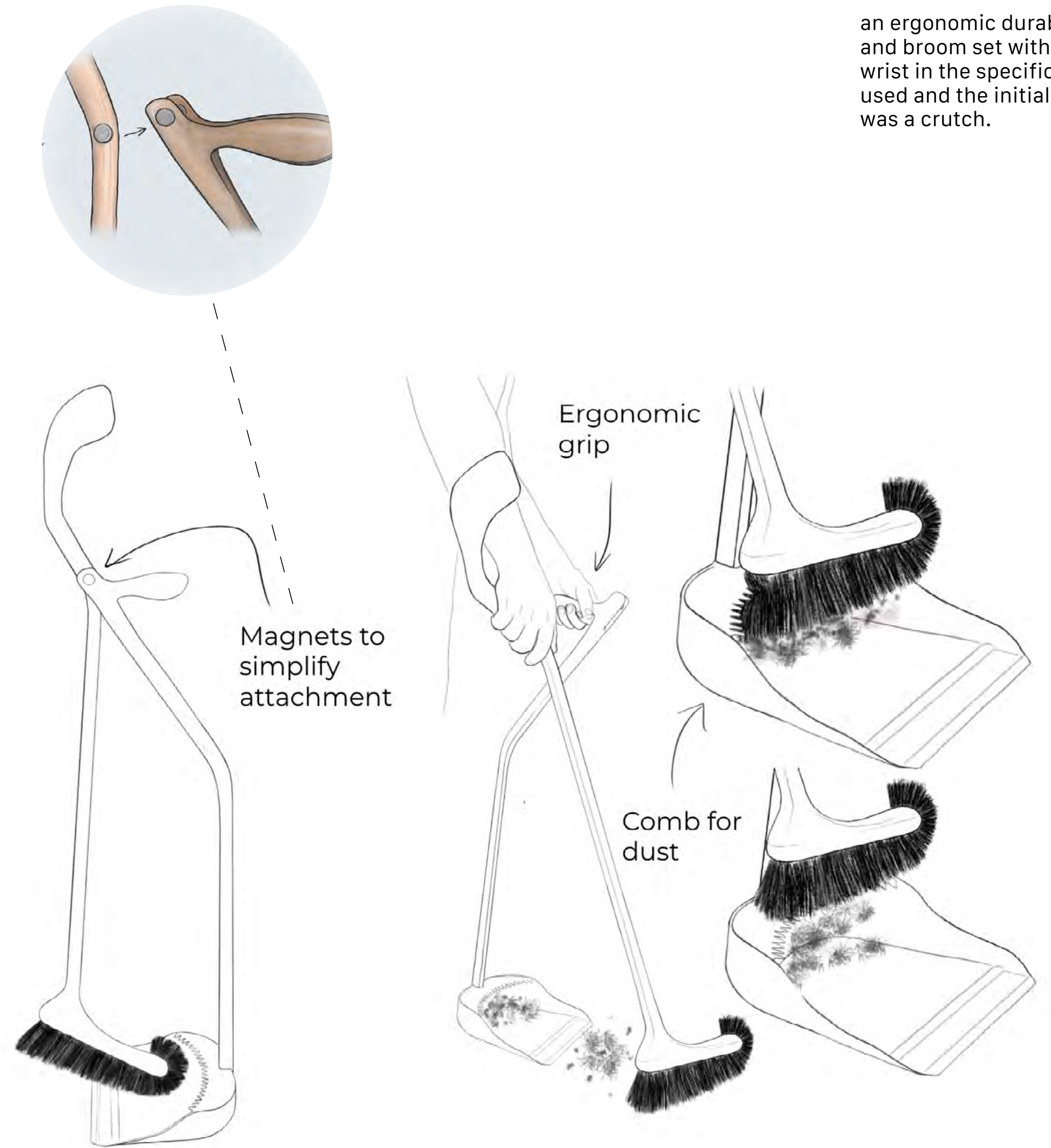



**MAGNETS**

- for effortless assembly



**THE EXTENSION**

- wrist relieving

**COMB**

- removes hair & dust



**WREB**  
Wrist Relieving Ergonomic Broom



# OTHER PROJECTS

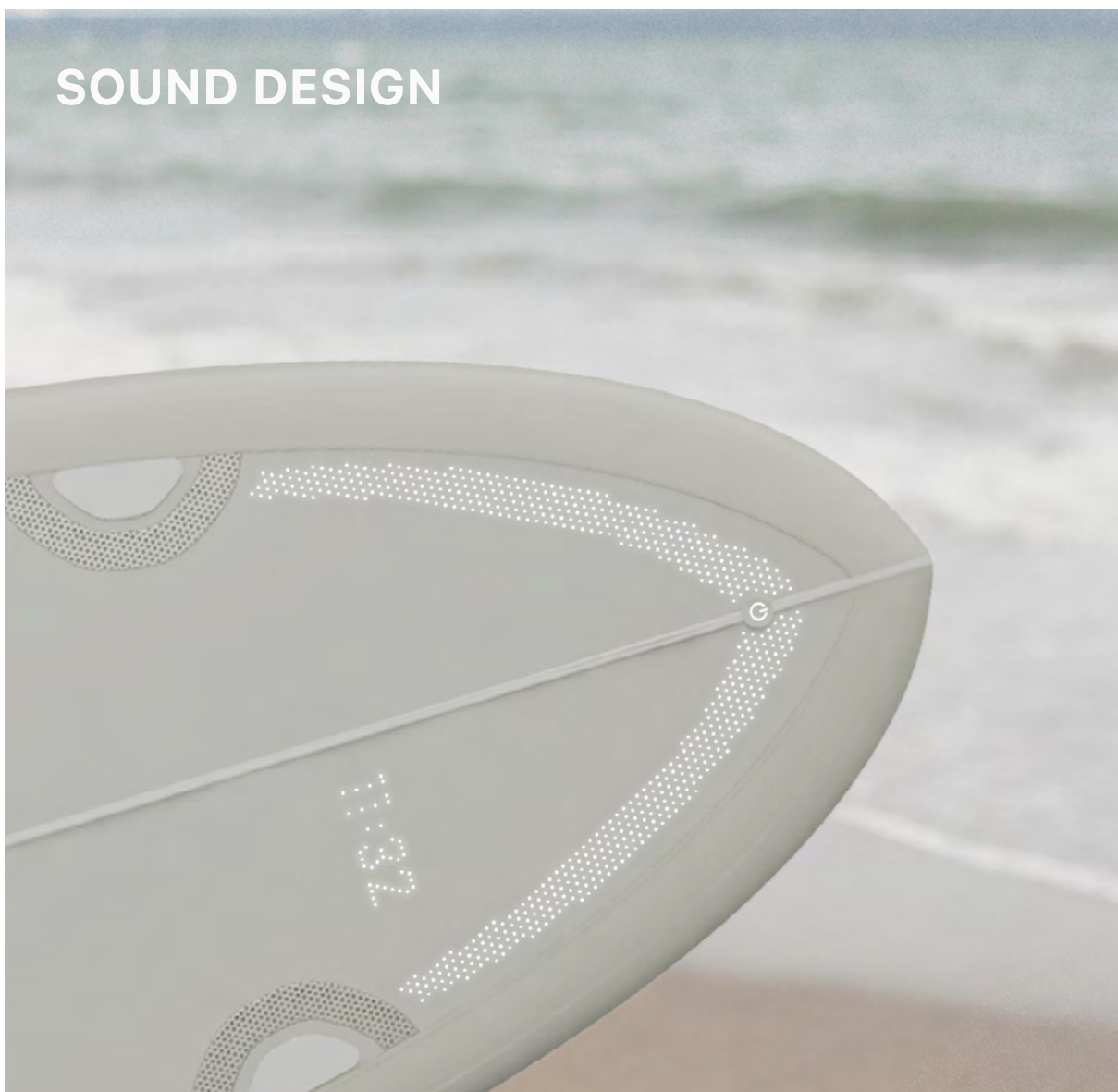

A collaborative sound design project with interaction design students, aimed at assisting new surfers in mastering wave timing.

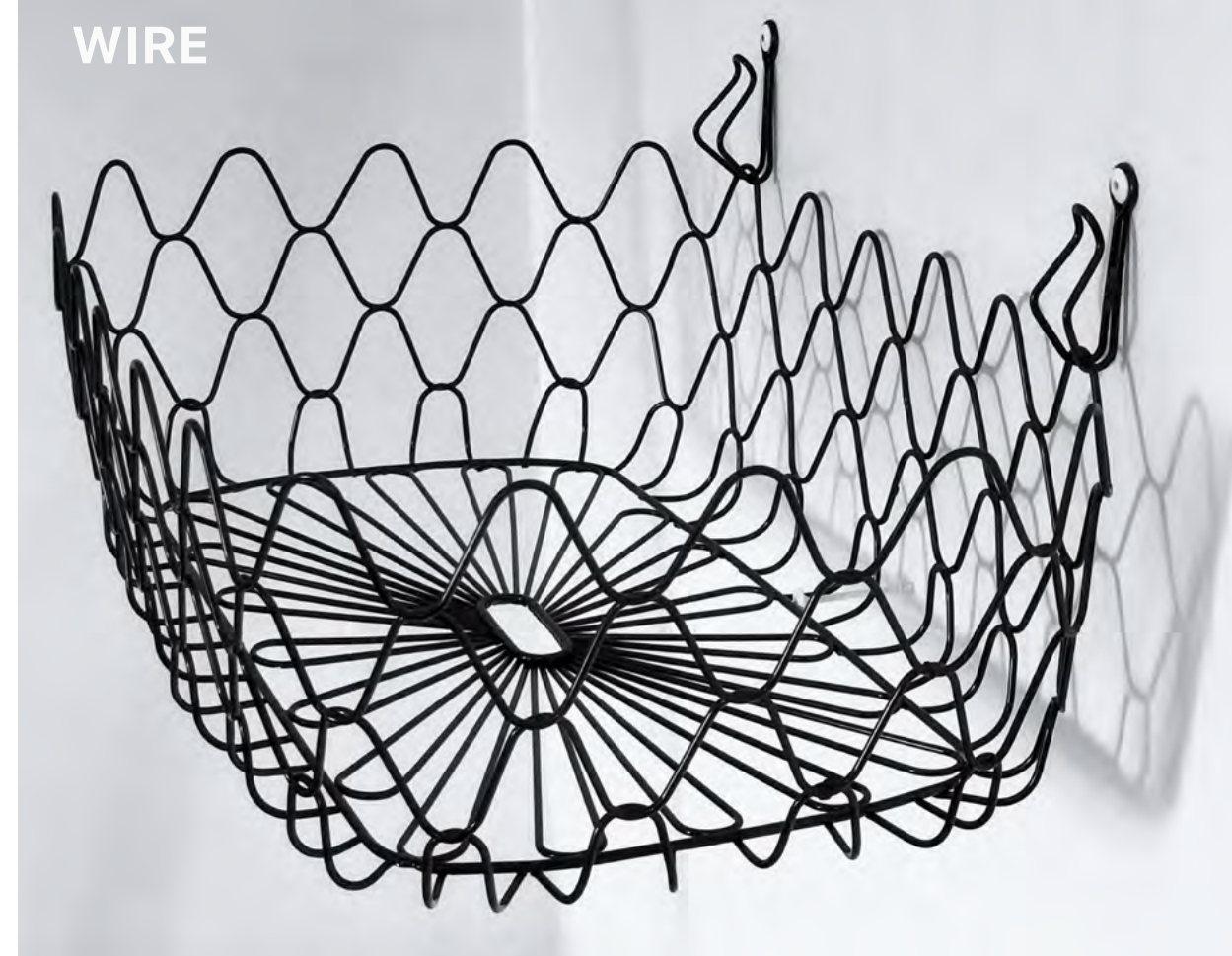

A project with focus on wire, welding and production



A product that helps elderly men when urinating seated



"Furniture in transformation". A remake of the monobloc chair, inspired by the Peacock chair by Hans Wegner



Packaging design for Perlweiss at Tatic Designstudio

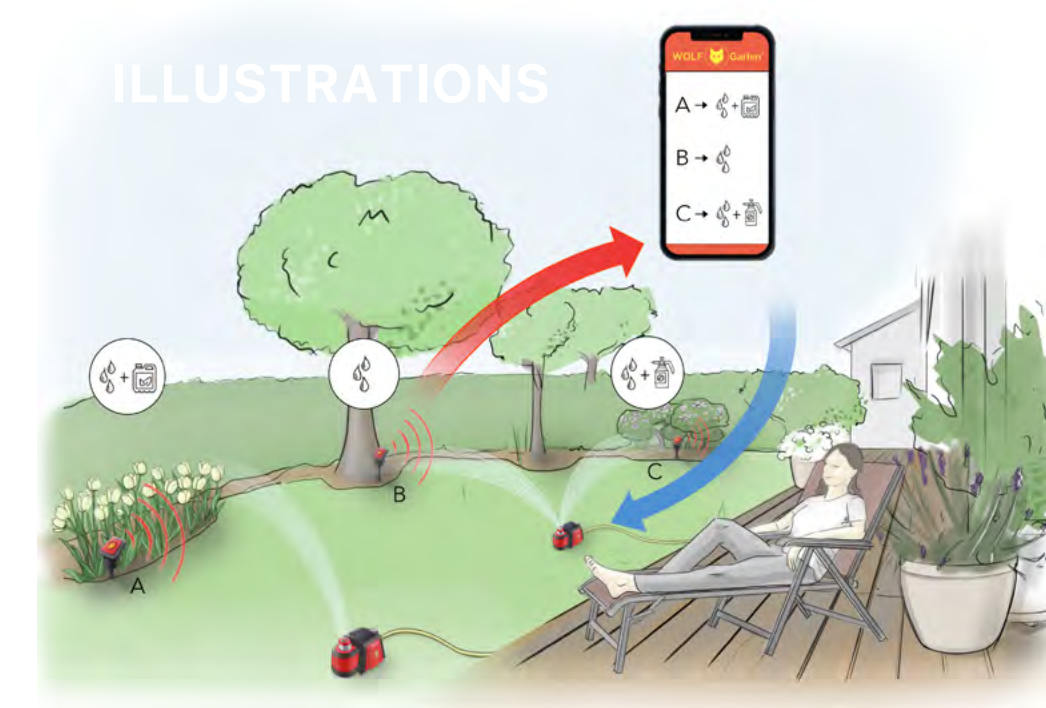

Scenario/innovation sketches for Wolf-Garten at Tatic Designstudio



An inserted support to effortlessly arrange flowers in the classic vase from Alvar Alto, designed together with Blomsterpigan, Malmö



# WHO AM I?



I am basically grown up in my parents flower shop in Malmö



I love outdoor activities



No workshop? No problem!  
I always find a way to make it work

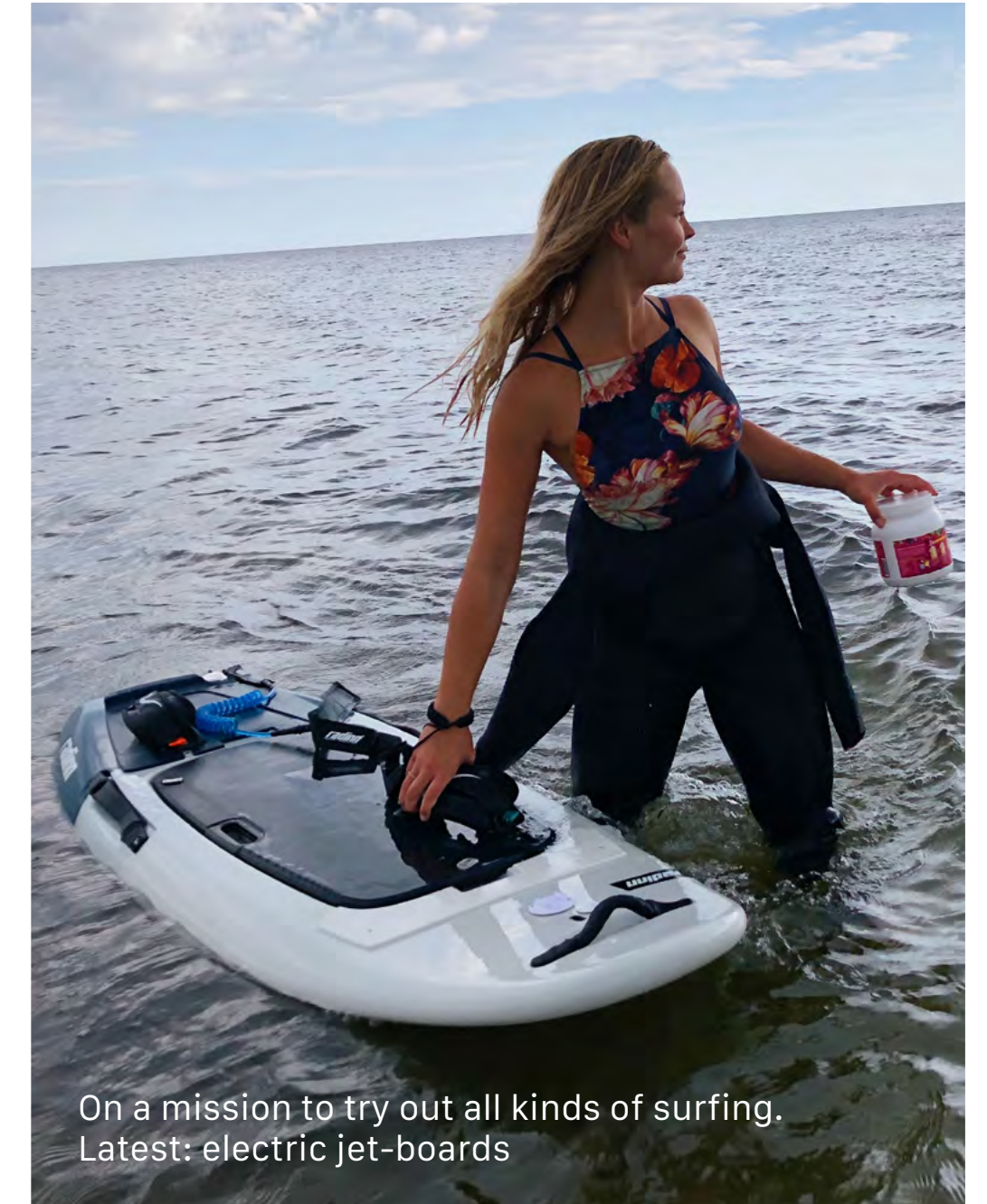

On a mission to try out all kinds of surfing.  
Latest: electric jet-boards



# WHY CHOOSE ME?

Beyond my design skills, I am committed to cultivating a positive work culture, as evidenced by my roles as a mood manager, event organizer, and versatile team contributor.

These experiences have honed my entrepreneurial skills and underscore my adaptability and commitment to personal and professional growth.

With a proactive mindset and a passion for new challenges, I am eager to join your team, bringing with me a track record of meaningful contributions and a readiness to embrace opportunities for innovation.

If you have any questions or would like to connect, please don't hesitate to reach out - I'm always open for a chat.



**Let's connect!**

LinkedIn: Frida Neckmar  
fridaneckmar@gmail.com  
+46708251040